

Grades 1-4 (S), 5-8 (S), 9-12 (S)

Duration: 45 min

Tools: two Logifaces Sets and two triangular grids / Pair

Pair work

Keywords: Battleship

107 - Battleship Game

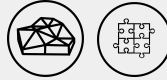

MATHS / GAME



LOGIFACES
METHODOLOGY
Erasmus+

TEACHER
Logifaces

2019-1-HU01-KA201-0612722019-1

DESCRIPTION

The game is similar to battleship, but played on a special triangular grid (which can be found at the end of the exercise). The groups build a structure out of Logifaces blocks and the players have to guess the opponent's structure.

Preparation before the game:

Each student gets a Logifaces Set and builds a structure (without the opponent seeing it) with a smooth surface using all the pieces of the Logifaces set. Holes are allowed in the structures, but all the pieces have to be connected by vertical faces (no corner connections or single blocks allowed). Students transfer the floor plan of their structure onto a triangular grid.

The game:

Students guess alternately in their pairs, just like in battleship. For example, the first student asks "Do you have a piece on "6A+" ?", if he/she thinks there could be a piece in the intersection of line "6" and "A", that is marked with a "+" (the + marking is needed as 6A could mean 2 triangles). If it's a "hit", the student can mark the block in his/her grid and is allowed to guess again until he/she makes a wrong guess.

End of the game:

The game ends when a student creates a complete plan of the other student's structure. An additional task can be to build the structure of the other student according to the plan.

Possible extension:

If students indicate the heights of the vertical edges on their floor plan, their opponent could be asked to recreate their construction as well.

SOLUTIONS / EXAMPLES

See the figures for an example.

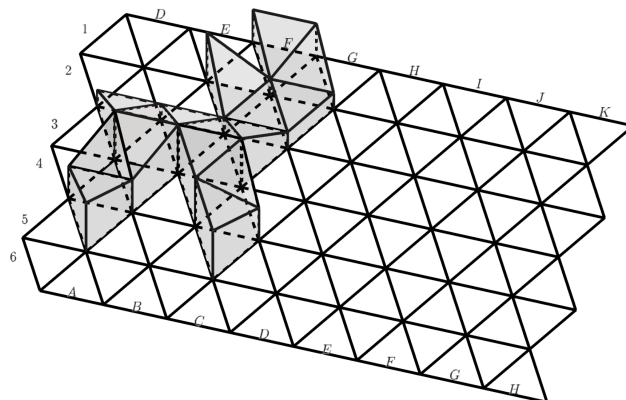
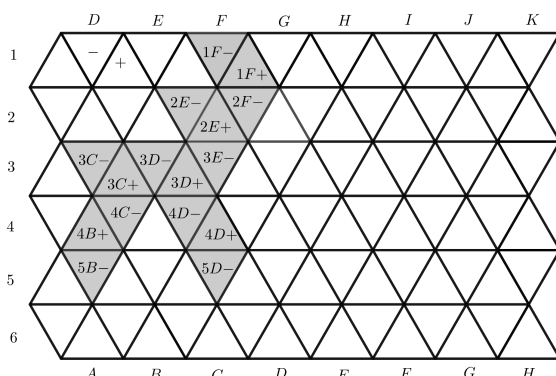

PRIOR KNOWLEDGE

None

RECOMMENDATIONS / COMMENTS

It's a fun game to play on special occasions or to get familiar with the Logifaces pieces. It can develop logical thinking skills.

If there aren't enough sets to give to each student, the sets can be passed around after the floor plans are created. Indicating the heights will help students to recreate their constructions if needed.

