

## Lesson 10: Drawing triangles (Part 2)

### Goals

- Draw triangles with two given side lengths and one angle size or three given angle sizes, and describe (orally) how many different triangles could be drawn with the given conditions.
- Use drawings to justify (in writing) whether two given side lengths and one angle size determine one unique triangle.

### Learning Targets

- Given two side lengths and one angle size, I can draw different triangles with these measurements or show that these measurements determine one unique triangle or no triangle.

### Lesson Narrative

In this lesson, students continue their work from the previous lesson on drawing triangles with specified angle and side measurements. Whereas in the previous lesson they focused on two angles and a side length, in this lesson they focus on two side lengths and an angle, and on three angles. They continue to gain experience with compass, ruler, and protractor. They continue to notice from their drawings when the conditions determine one triangle, more than one, or none. Students are not expected to know rules about which conditions determine each possibility.

### Addressing

- Draw (freehand, with ruler and protractor, and with technology) geometric shapes with given conditions. Focus on constructing triangles from three measurements of angles or sides, noticing when the conditions determine a unique triangle, more than one triangle, or no triangle.

### Instructional Routines

- Stronger and Clearer Each Time
- Co-Craft Questions
- Think Pair Share

### Required Materials

#### Compasses

### Copies of blackline master

Revisiting how many can you draw?

Set your compass to 5 cm and then draw an arc:

from the left end of the 4 cm line segment      from the right end of the 4 cm line segment

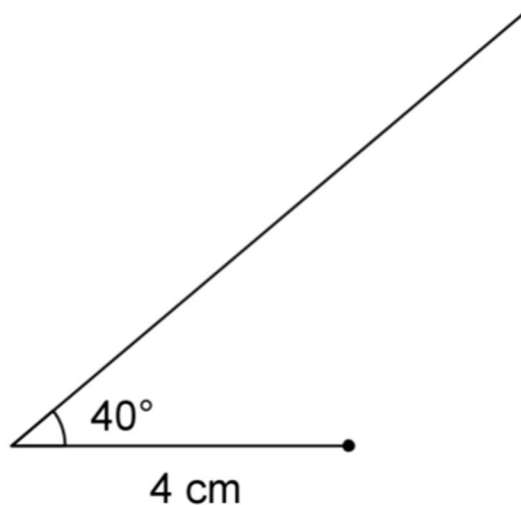
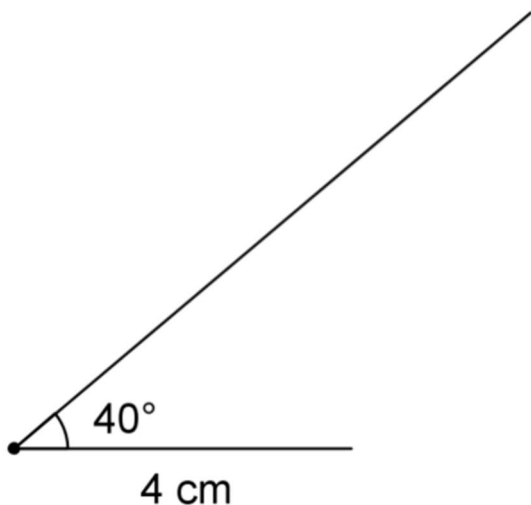

Set your compass to 4 cm and then draw an arc:

from the left end of the 5 cm line segment      from the right end of the 5 cm line segment

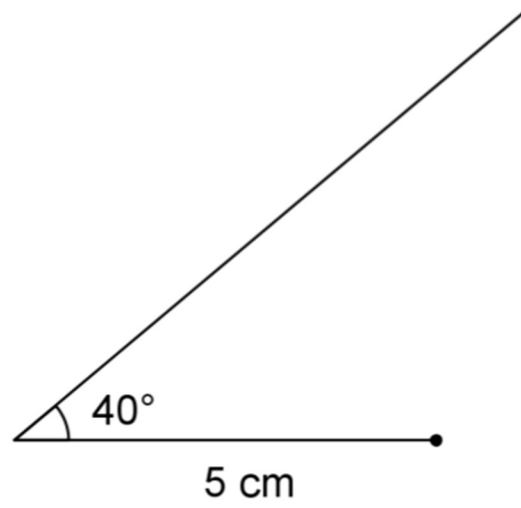
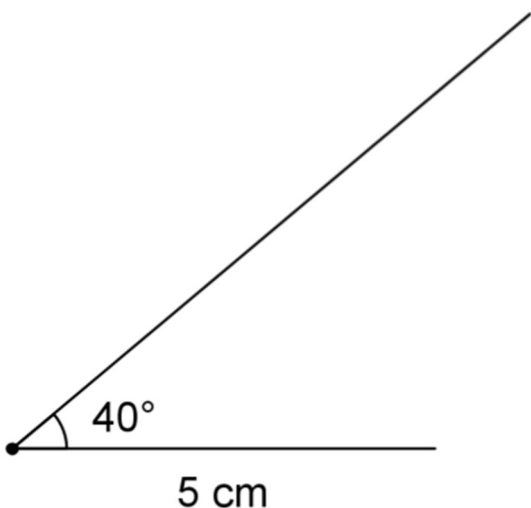

After you finish drawing and labelling each triangle, consider the following questions:

- Which two configurations made the same triangle?
- Which one configuration could make more than one triangle?

### Geometry toolkits

tracing paper, graph paper, coloured pencils, scissors, and an index card to use as a straightedge or to mark right angles, plus a ruler and protractor. Clear protractors with no holes and with radial lines printed on them are recommended.

---

## Required Preparation

To help students see how they can use a compass to draw different triangles with two of the same side lengths, you might choose to copy the How Many Can You Draw? blackline master for every student. This is optional.

## Student Learning Goals

Let's draw some more triangles.

## 10.1 Using a Compass to Estimate Length

### Warm Up: 5 minutes

The purpose of this warm-up is to remind students that a compass is useful for transferring a length in general, and not just for drawing circles. As students discuss answers with their partners, monitor for students who can clearly explain how they can use the compass to compare the length of the third side.

### Launch

Arrange students in groups of 2. Give students 2 minutes of quiet work time followed by time to discuss their answers with their partner. Follow with a whole-class discussion. Provide access to geometry toolkits and compasses.

### Student Task Statement

1. Draw a  $40^\circ$  angle.
2. Use a compass to make sure both sides of your angle have a length of 5 centimetres.
3. If you connect the ends of the sides you drew to make a triangle, is the third side longer or shorter than 5 centimetres? How can you use a compass to explain your answer?

### Student Response

1. and 2.

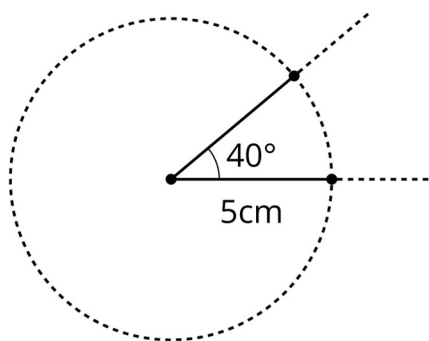

3. The third side is shorter than 5 cm. I know this because I can use my compass that is set to a radius of 5 cm and place it at the end of one of the two sides. When I draw

---

another circle, the end of the other side of the angle is inside, so the distance between the two ends must be less than 5 cm.

### Activity Synthesis

Ask previously identified students to share their responses to the final question. Display their drawing of the angle for all to see. If not mentioned in students' explanations, demonstrate for all to see how to use the compass to estimate the length of the third side of the triangle.

## 10.2 Revisiting How Many Can You Draw?

### 15 minutes (there is a digital version of this activity)

Students continue to practise drawing triangles from given conditions and categorising their results. This activity focuses on the inclusion of a single angle and two sides. Again, they do not need to memorise which conditions result in unique triangles, but should begin to notice how some conditions (such as the equal side lengths) result in certain requirements for the completed triangle.

There is an optional blackline master that can help students organise their work at trying different configurations of the first set of measurements. If you provide students with a copy of the blackline master, ask them to determine whether any of the configurations result in the same triangle, as well as whether any one configuration results in two possible triangles.

### Instructional Routines

- Stronger and Clearer Each Time
- Co-Craft Questions

### Launch

Keep students in same groups. Remind students of the activity in a previous lesson where they used the strips and fasteners to draw triangles on their paper. Ask what other tool also helps you find all the points that are a certain distance from a centre point (a compass). Distribute optional blackline masters if desired. Provide access to geometry toolkits and compasses.

Give students 7–8 minutes of partner work time, followed by a whole-class discussion.

If students have access to digital activities there is an applet that allows for triangle construction.

*Reading, Speaking: Co-craft Questions.* Display just the statement: "One angle measures 40 degrees, one side measures 4 cm, and one side measures 5 cm." Invite students to write down possible mathematical questions that could be asked with this information. Ask students to compare the questions generated with a partner before selecting 1–2 groups to share their questions with the class. Listen for the ways the given conditions are used or

referenced in students' questions. This routine will help students to understand the context of this problem before they are asked to create a drawing.

*Design Principle(s): Maximise meta-awareness; Cultivate conversation*

### Anticipated Misconceptions

Some students may draw two different orientations of the same triangle for the first set of conditions, with the  $40^\circ$  angle in between the 4 cm and 5 cm sides. Prompt them to use tracing paper to check whether their two triangles are really different (not identical copies).

If students struggle to create more than one triangle from the first set of conditions, prompt them to write down the order they already used for their measurements and then brainstorm other possible orders they could use.

### Student Task Statement

1. Draw as many different triangles as you can with each of these sets of measurements:
  - a. One angle measures  $40^\circ$ , one side measures 4 cm, and one side measures 5 cm.
  - b. Two sides measure 6 cm, and one angle measures  $100^\circ$ .
2. Did either of these sets of measurements determine one unique triangle? How do you know?

### Student Response

1. Drawings vary. Sample responses:
  - a. There are 4 different triangles that can be drawn from the given conditions.

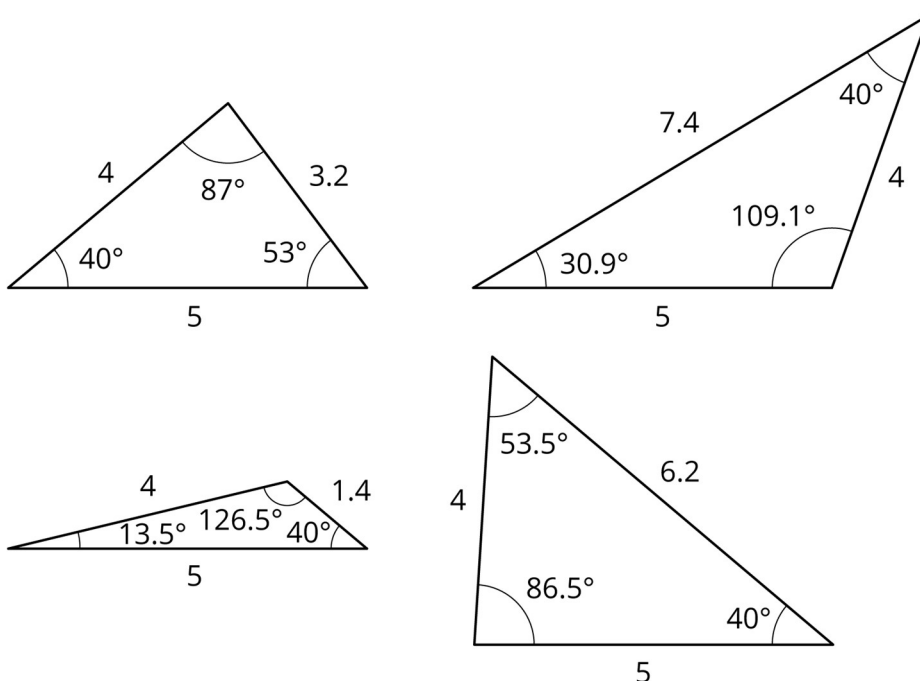

- b. There is only one triangle that can be drawn from the given conditions.

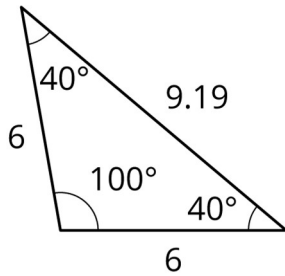

2. The second set of measurements determined one unique triangle. There was no other way I could draw it.

### Activity Synthesis

Ask one or more students to share how many different triangles they were able to draw with each set of conditions. Select students to share their solutions.

If not brought up in student explanations, point out that for the first problem, one possible order for the measurements ( $40^\circ$ , 5 cm, 4 cm) can result in two different triangles (the bottom two in the solution image). One way to show this is to draw a 5 cm line segment and then use a compass to draw a circle with a 4 cm radius centred on the line segment's left endpoint. Next, draw a ray at a  $40^\circ$  angle centred on the line segment's right endpoint. Notice that this ray intersects the circle twice. Each one of these points could be the third vertex of the triangle. While it is helpful for students to notice this interesting aspect of their drawing, it is *not* important for students to learn rules about the number of possible triangles given different sets of conditions.

If the optional blackline master was used, ask students:

- “Which configurations made identical triangles?” (the top left and bottom left)
- “Which configurations made more than one triangle?” (the bottom right)

If not mentioned by students, explain to students that the top left and bottom left configurations result in the same triangle, because in both cases the  $40^\circ$  angle is in between the 4 cm and 5 cm sides and that the bottom right configuration results in two different triangles, because the arc intersects the ray in two different places.

*Stronger and Clearer Each Time:* Before discussing the second set of conditions as a whole class, have student pairs share their reasoning for why there were no more triangles that could be drawn with the given measures, with two different partners in a row. Have students practice using mathematical language to be as clear as possible when sharing with the class, when and if they are called upon.

*Engagement: Develop Effort and Persistence.* Break the class into small group discussion groups and then invite a representative from each group to report back to the whole class.  
*Supports accessibility for: Attention; Social-emotional skills*

---

## 10.3 Three Angles

### 15 minutes (there is a digital version of this activity)

This activity focuses on including three angle conditions. The goal is for students to notice that some angle conditions result in a large number of possible triangles (all scaled copies of one another) or are impossible to create. Students are not expected to learn that the angles must sum to 180 degrees in a triangle, but are not barred from noticing this fact.

#### Instructional Routines

- Stronger and Clearer Each Time
- Think Pair Share

#### Launch

Arrange students in groups of 2. Tell students that they should attempt to create a triangle with the given specifications. If they can create one, they should attempt to either create at least one more or justify to themselves why there is only one. If they cannot create any, they should show some valid attempts to include as many pieces as they can and be ready to explain why they cannot include the remaining conditions.

Give students 5 minutes of quiet work time followed by time to discuss the triangles they could make with a partner. Follow with a whole-class discussion. Provide access to geometry toolkits and compasses.

If using the digital lesson, students should still try to create a triangle with the given specifications. If they can create one, they should attempt to either create at least one more or justify to themselves why there is only one. If they cannot create any, they should be ready to explain some of their attempts and why they cannot include the remaining conditions.

#### Anticipated Misconceptions

If students struggle to get started, remind them of Lin’s technique of using the protractor and a ruler to make an angle that can move along a line.

#### Student Task Statement

1. Draw as many different triangles as you can with each of these sets of measurements:
  - a. One angle measures  $50^\circ$ , one measures  $60^\circ$ , and one measures  $70^\circ$ .
  - b. One angle measures  $50^\circ$ , one measures  $60^\circ$ , and one measures  $100^\circ$ .
2. Did either of these sets of measurements determine one unique triangle? How do you know?

#### Student Response

- 1.
-

a. Answers vary. Sample response:

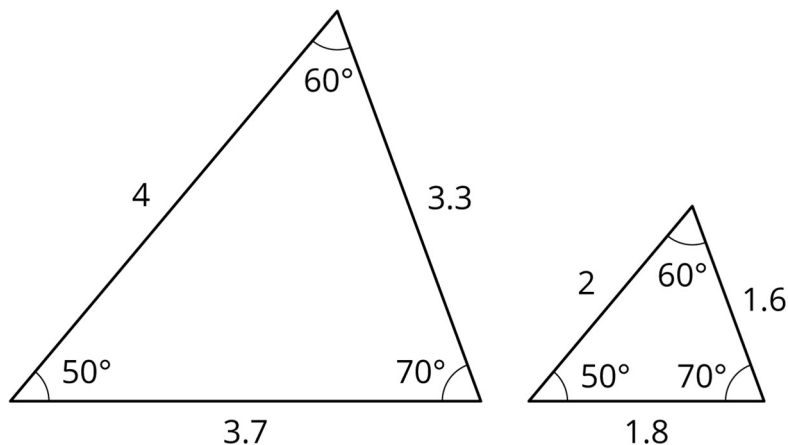

There are many possible triangles that can be made with these angle measurements, because we don't know any of the side lengths. All the possible triangles are scaled copies of each other.

- b. There is no way to draw a triangle with these angle measurements, because once the first two angles are drawn, the third angle is already set.
- If I start with 50° and 60°, then the third angle is always 70°. I can't make it 100°.
  - If I start with 50° and 100°, then the third angle is always 30°. I can't make it 60°.
  - If I start with 60° and 100°, then the third angle is always 20°. I can't make it 50°.

2. Neither of these sets of measurements determine 1 unique triangle.

### Are You Ready for More?

Using *only* a compass and the edge of a blank index card, draw a perfectly equilateral triangle. (Note! The tools are part of the challenge! You may not use a protractor! You may not use a ruler!)

### Student Response

Draw a line segment and label the endpoints  $A$  and  $B$ . Open compass so that the radius is the same length as the line segment you drew. Place pointy end of compass on  $A$ , swing arc. Put pointy end on  $B$ , swing arc. Intersection of arcs is the other vertex of the equilateral triangle.

### Activity Synthesis

Select students to share their drawings and display them for all to see. Ask students:



- 
- “Were there any sets of measurements that produced a unique triangle?” (no)
  - “Which combinations of angles could not be drawn?” (the angles in the second problem,  $50^\circ$ ,  $60^\circ$ ,  $100^\circ$ )
  - “Why is there more than one triangle that can be made with the measurements in the first problem?” (because there are no side lengths mentioned, so we can create scaled copies of the triangles with the same angles but with shorter or longer side lengths)

*Stronger and Clearer Each Time:* Before discussing the second set of conditions as a whole class, have student pairs share their reasoning for why there were no triangles that could be drawn with the given measurements, with two different partners in a row. Have students practise using mathematical language to be as clear as possible when sharing with the class, when and if they are called upon.

### Lesson Synthesis

- How was a compass useful in drawing triangles today? (It helps find all the points a certain distance away.)
- What strategies did you use to include two given side lengths and a given angle? (Draw one of the side lengths and use a protractor to draw the angle at one end, then use a compass to finish the picture.)
- What strategies did you use to include three given angles? (Draw one angle then use a protractor and ruler to slide along one side of the first angle.)

## 10.4 Finishing Noah’s Triangle

**Cool Down: 5 minutes**

### Student Task Statement

Noah is trying to draw a triangle with a  $30^\circ$  angle and side lengths of 4 cm and 6 cm.

- He uses his ruler to draw a 4 cm line segment.
- He uses his protractor to draw a  $30^\circ$  angle on one end of the line segment.

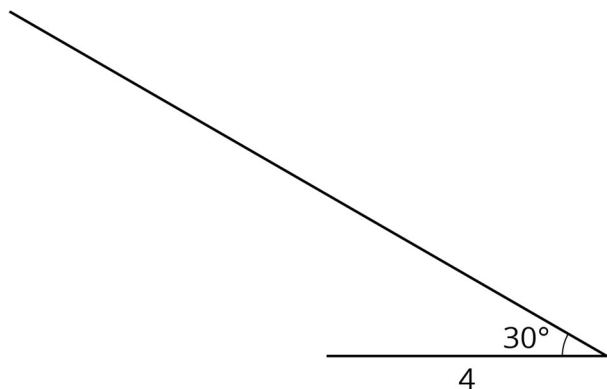

1. What should Noah do next? Explain and show how he can finish drawing the triangle.
2. Is there a different triangle Noah could draw that would answer the question? Explain or show your reasoning.

### Student Response

1. Noah should use a compass to draw a circle with radius 6 cm and centre at one end of the 4 cm side. He should then draw line segments connecting both ends of the 4 cm side to the point where the circle and ray cross to complete the triangle.
2. Yes. Noah could try beginning with the same setup he has already drawn again, but this time centre the circle on the other end of the 4 cm side. He could also start with the 6 cm side drawn instead of the 4 cm side and follow the same process.

### Student Lesson Summary

A triangle has six measurements: three side lengths and three angles.

If we are given three measurements, then sometimes, there is no triangle that can be made. For example, there is no triangle with side lengths 1, 2, 5, and there is no triangle with all three angles measuring  $150^\circ$ .

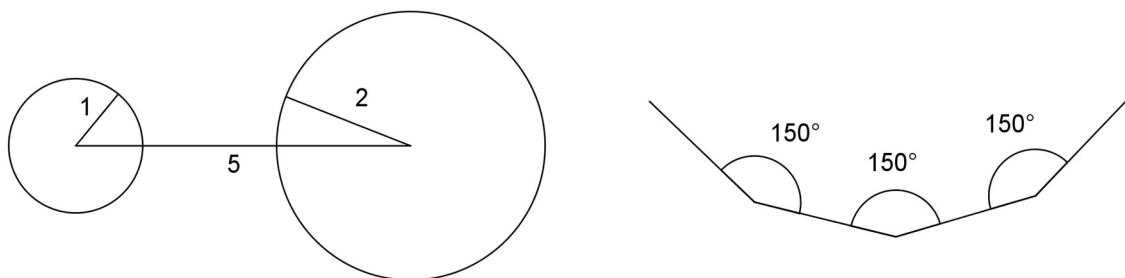

Sometimes, only one triangle can be made. By this we mean that any triangle we make will be the same, having the same six measurements. For example, if a triangle can be made with three given side lengths, then the corresponding angles will have the same sizes. Another example is shown here: an angle measuring  $45^\circ$  between two side lengths of 6 and 8 units. With this information, one unique triangle can be made.

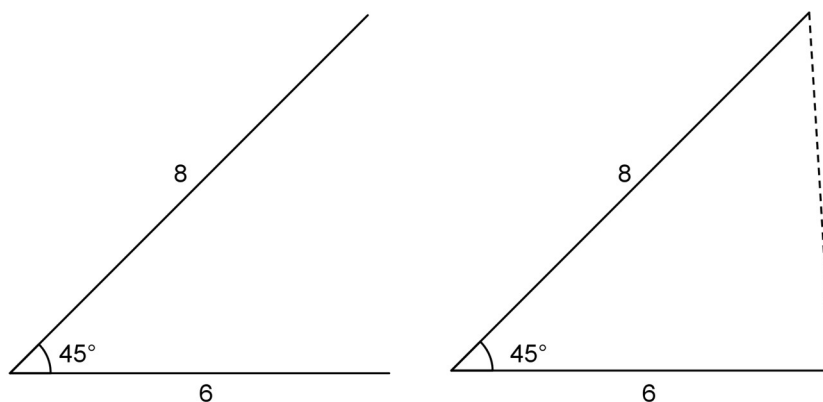

Sometimes, two or more different triangles can be made with three given measurements. For example, here are two different triangles that can be made with an angle measuring  $45^\circ$  and side lengths 6 and 8. Notice the angle is not between the given sides.

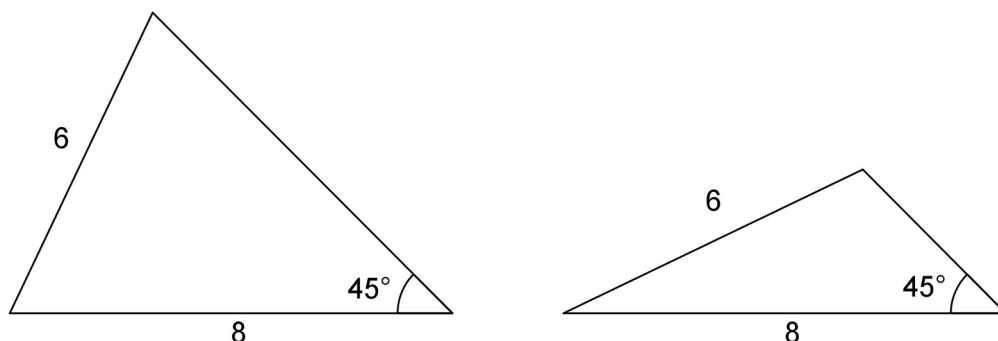

Three pieces of information about a triangle's side lengths and angles may determine no triangles, one unique triangle, or more than one triangle. It depends on the information.

## Lesson 10 Practice Problems

### 1. Problem 1 Statement

A triangle has sides of length 7 cm, 4 cm, and 5 cm. How many unique triangles can be drawn that fit that description? Explain or show your reasoning.

#### Solution

You can only draw one unique triangle with those same 3 measurements. If you start by drawing the 7 cm side and then draw circles of radii 4 cm and 5 cm at each endpoint, the circles will cross at two places. Connecting the endpoints of the 7 cm side to those crossing points will produce two identical triangles, each having side lengths 7 cm, 4 cm, and 5 cm. There are no other points that could be the third vertex of the triangle.

### 2. Problem 2 Statement

A triangle has one side that is 5 units long and an adjacent angle that measures  $25^\circ$ . The two other angles in the triangle measure  $90^\circ$  and  $65^\circ$ . Complete the two diagrams to create two *different* triangles with these measurements.

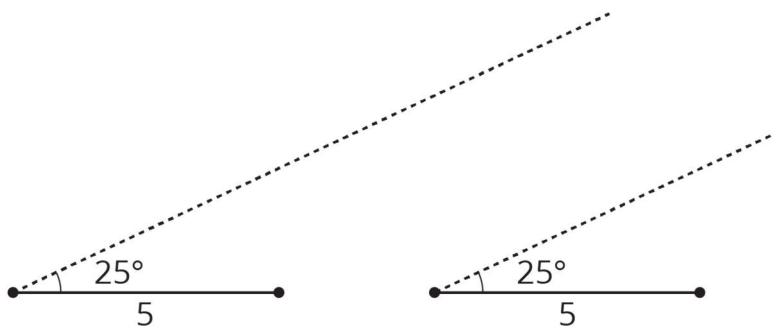

**Solution**

Answers vary.

**3. Problem 3 Statement**

Is it possible to make a triangle that has angles measuring 90 degrees, 30 degrees, and 100 degrees? If so, draw an example. If not, explain your reasoning.

**Solution**

No, if you try to draw a triangle that has a 90 degree angle on the end of a side and a 100 degree angle on the other end of the same side, there is no way to make the other two sides meet to form a triangle.

**4. Problem 4 Statement**

Line segments  $CD$ ,  $AB$ , and  $FG$  intersect at point  $E$ . Angle  $FEC$  is a right angle. Identify any pairs of angles that are complementary.

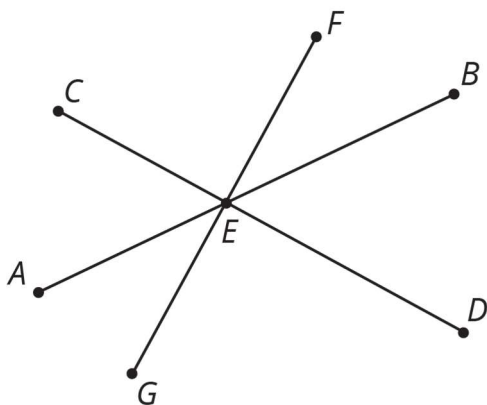

**Solution**

- $FEB$  and  $DEB$
- $CEA$  and  $AEG$

These are also complementary, but students may not have the tools to identify them yet:

- $FEB$  and  $CEA$
- $DEB$  and  $AEG$

**5. Problem 5 Statement**

Match each equation to a step that will help solve the equation for  $x$ .

A.  $3x = -4$

---

B.  $-4.5 = x - 3$

C.  $3 = \frac{-x}{3}$

D.  $\frac{1}{3} = -3x$

E.  $x - \frac{1}{3} = 0.4$

F.  $3 + x = 8$

G.  $\frac{x}{3} = 15$

H.  $7 = \frac{1}{3} + x$

1. Add  $\frac{1}{3}$  to each side.
2. Add  $\frac{-1}{3}$  to each side.
3. Add 3 to each side.
4. Add -3 to each side.
5. Multiply each side by 3..
6. Multiply each side by -3.
7. Multiply each side by  $\frac{1}{3}$ .
8. Multiply each side by  $\frac{-1}{3}$ .

**Solution**

- A: 7
  - B: 3
  - C: 6
  - D: 8
  - E: 1
  - F: 4
  - G: 5
  - H: 2
-

## 6. Problem 6 Statement

- a. If you deposit £300 in an account with a 6% interest rate, how much will be in your account after 1 year?
- b. If you leave this money in the account, how much will be in your account after 2 years?

### Solution

- a. £318
- b. £337.08



© These materials were derived and adapted from Illustrative Mathematics's IM 6–8 Math™. IM 6–8 Math was originally developed by Open Up Resources and authored by Illustrative Mathematics®, and is copyright 2017–2019 by Open Up Resources. It is licensed under the Creative Commons Attribution 4.0 International License (CC BY 4.0) <https://creativecommons.org/licenses/by/4.0/>. OUR's 6–8 Math Curriculum is available at <https://openupresources.org/math-curriculum/>. Adaptations and updates to IM 6–8 Math™ are copyright 2019 by Illustrative Mathematics®, and are licensed under the Creative Commons Attribution 4.0 International License (CC BY 4.0). Further adaptations have been made by MEI.