

Lesson 5: Using equations to solve for unknown angles

Goals

- Critique whether a given equation represents the relationship between angles in a diagram.
- Solve an equation that represents a relationship between the sizes of angles, and explain (in writing and using other representations) the reasoning.
- Write an equation of the form $px + q = r$ or $p(x + q) = r$ to represent the relationship between angles in a given diagram.

Learning Targets

- I can write an equation to represent a relationship between the sizes of angles and solve the equation to find unknown angles.

Lesson Narrative

In the previous lesson, students saw that equations could be used to represent relationships between angles. In this lesson, students practise writing and solving equations of the form $px + q = r$ in the context of finding unknown angles. This brings together their work with equations from the previous unit and their work with angles from earlier lessons in this unit, giving students a chance to build fluency with both of these concepts.

Building On

- Use variables to represent quantities in a real-world or mathematical problem, and construct simple equations and inequalities to solve problems by reasoning about the quantities.

Addressing

- Use variables to represent quantities in a real-world or mathematical problem, and construct simple equations and inequalities to solve problems by reasoning about the quantities.
- Use facts about supplementary, complementary, vertical, and adjacent angles in a multi-step problem to write and solve simple equations for an unknown angle in a diagram.

Instructional Routines

- Stronger and Clearer Each Time
 - Discussion Supports
 - Think Pair Share
-

Student Learning Goals

Let's figure out missing angles using equations.

5.1 Is This Enough?

Warm Up: 5 minutes

In this activity, students consider whether there is enough information given to solve for the unknown angles. In previous lessons, students were given some angles in a diagram and asked to solve for another. In this warm-up, the diagram contains two unknowns and students are asked to critique Tyler's thinking.

The discussion addresses the case in which angles a and b are equal to each other, in preparation for future activities in this lesson that have multiple unknown angles with the same size. Monitor for students who agree and disagree with Tyler's thinking, and ask them to share during the discussion.

Instructional Routines

- Think Pair Share

Launch

Arrange students in groups of 2. Give students 1 minute of quiet think time followed by time to discuss their reasoning with their partner. Follow with a whole-class discussion.

Anticipated Misconceptions

Some students may want to use tools from their geometry toolkits to measure the angles. Explain that the question is asking if they can solve the problem by only looking at the diagram, not by measuring it.

Student Task Statement

Tyler thinks that this diagram has enough information to figure out the values of a and b .

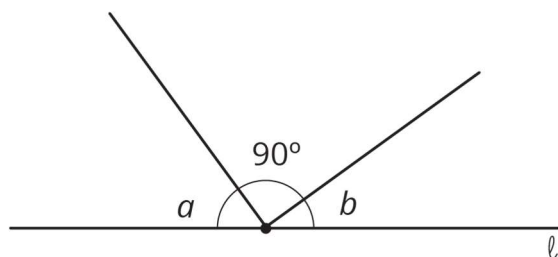

Do you agree? Explain your reasoning.

Student Response

I disagree with Tyler. Sample reasoning: We don't know how much bigger a is than b . All we know for sure is that $a + b = 90$.

Activity Synthesis

Poll the class on whether or not they agree with Tyler. Invite students to share their reasoning until they reach an agreement that Tyler is incorrect.

Ask students to come up with an equation to represent the angles in the diagram. ($a + 90 + b = 180$ or equivalent) Record their answers for all to see.

Display this image. Invite students to share how this diagram is the same as the diagram from the task and how it is different.

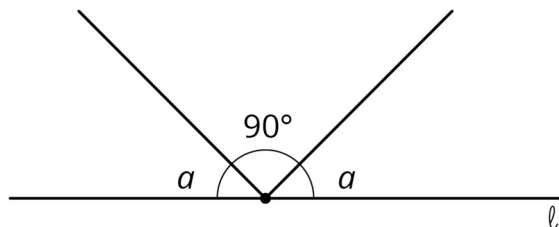

If students do not mention any of these points, make sure to point them out:

- Some things that are the same are the fact that there are still two unknown angles and the three angles sum to 180 degrees. The two unknown angles are still complementary.
- The main difference is that the two unknown angles are the same.
- This diagram can be represented with the equation $a + 90 + a = 180$ or equivalent.
- Because both unknown angles have the same size, we have enough information to know the value of a .
- $a = 45$

5.2 What Does It Look Like?

15 minutes

The purpose of this activity is for students to practise solving equations that represent relationships between angles, in preparation for the next activity where students will write such equations themselves.

The last three diagrams include right angles, but they are not marked (except that the task statement says to assume angles that look like right angles are right angles). This may come up in discussion after students have had time to work.

Instructional Routines

- Stronger and Clearer Each Time
- Think Pair Share

Launch

Tell students that each diagram has two possible equations, and their job is to choose the equation that best represents a relationship between angles in the diagram. Then, solve their chosen equation.

Keep students in the same groups. Give 5 minutes of quiet work time followed by time to discuss reasoning with a partner. Follow with a whole-class discussion.

Representation: Internalise Comprehension. Activate or supply background knowledge by asking students to start by labelling any angles they can find with their size in degrees.

Allow students to use calculators to ensure inclusive participation in the activity.

Supports accessibility for: Memory; Conceptual processing

Anticipated Misconceptions

If students struggle working with equations, encourage them to start with the diagram and label any angles they can figure out with their size in degrees. The thinking necessary to figure out the sizes of other angles may help them recognise a corresponding equation.

Prompt students to recall what it looks like when an angle measures 90 degrees and what it looks like when an angle measures 180 degrees.

Student Task Statement

Elena and Diego each wrote equations to represent these diagrams. For each diagram, decide which equation you agree with, and solve it. You can assume that angles that look like right angles are indeed right angles.

1. Elena: $x = 35$

Diego: $x + 35 = 180$

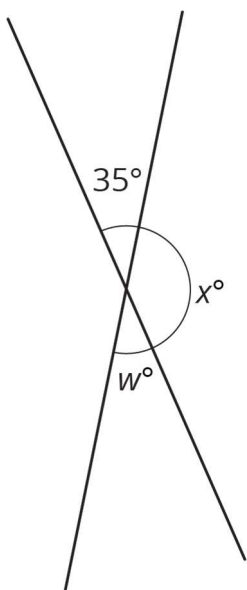

2. Elena: $35 + w + 41 = 180$

Diego: $w + 35 = 180$

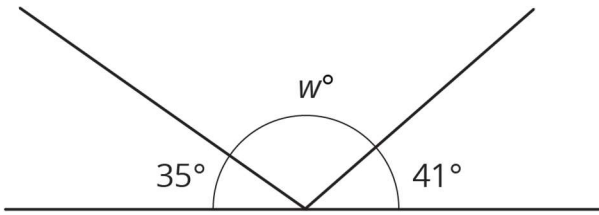

3. Elena: $w + 35 = 90$

Diego: $2w + 35 = 90$

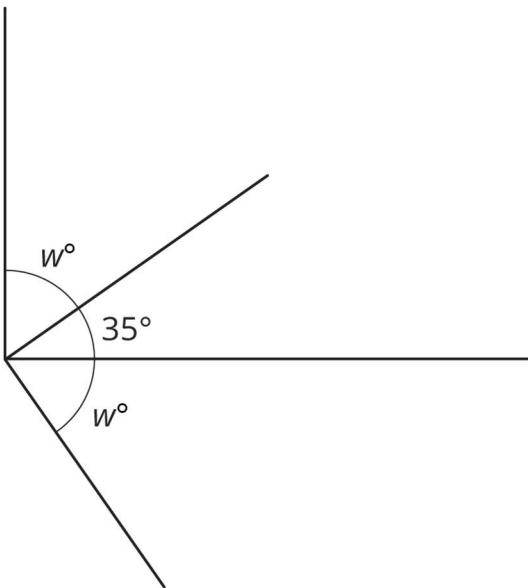

4. Elena: $2w + 35 = 90$

Diego: $w + 35 = 90$

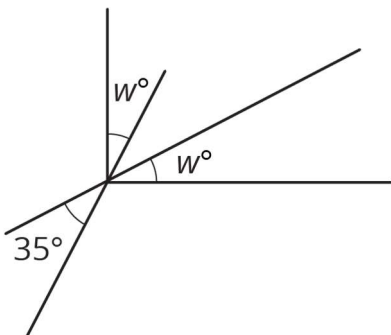

5. Elena: $w + 148 = 180$

Diego: $x + 90 = 148$

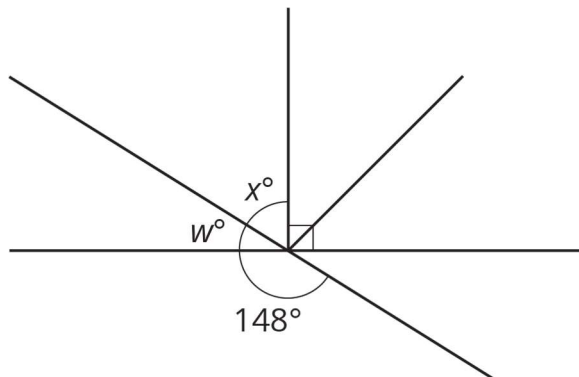

Student Response

1. Diego's equation: $x + 35 = 180$. Solution: 145.
2. Elena's equation: $35 + w + 41 = 180$. Solution: 104.
3. Elena's equation: $w + 35 = 90$. Solution: 55.
4. Elena's equation: $2w + 35 = 90$. Solution: 27.5.
5. Both equations. $w = 32$ and $x = 58$.

Activity Synthesis

Select students to share equations they agreed with and angles they found for each problem. As students share their explanations consider asking these questions:

- "Where do you see the relationship expressed in the equation in the given diagram? (and vice versa)"
- "Did you and your partner agree on the equations and angle sizes?"

For the last question, have students who used different equations to figure out the unknown angles share their explanations. Ask students:

- "What angle relationship did you need to recognise to use Elena's equation?" (That the angle with a size of w degrees and the angle measuring 148 degrees were supplementary.)
- "What angle relationship did you need to recognise to use Diego's equation?" (That the angle measuring 148 degrees formed a vertically opposite angle with the right angle and the angle measuring x degrees.)
- "Does either method get us the same answer for both unknown angles?" (Yes.)

Explain to students that there might be multiple ways to get an answer because of the many angle relationships found in some diagrams. Encourage them to look for different methods in the next activity.

Speaking: Stronger and Clearer Each Time. Use this routine to provide students with a structured opportunity to refine their explanations about whether or not they agree with Tyler. Give students time to meet with 2–3 partners, to share and get feedback on their responses. Provide prompts for feedback that will help students strengthen their ideas and clarify their language (e.g., “Can you give an example?”, “Why do you think...?”, “Can you say that another way?”, etc.). Give students 1–2 minutes to revise their writing based on the feedback they received.

Design Principle(s): Optimise output (for explanation)

5.3 Calculate the size

10 minutes

This activity is a culmination of all the work students have done with angles in this unit. With less support than in previous activities, students come up with equations that represent the relationships between angles in a diagram. Then, students solve their equation to find each unknown angle.

Instructional Routines

- Discussion Supports

Launch

Encourage students to write an equation for each problem. Give students 2–3 minutes of quiet work time followed by a whole-class discussion.

Representation: Internalise Comprehension. Activate or supply background knowledge by asking students to start by looking for any vertical, complementary and supplementary angles. Allow students to use calculators to ensure inclusive participation in the activity.
Supports accessibility for: Memory; Conceptual processing

Anticipated Misconceptions

If students struggle to see the angle relationships in the diagrams, prompt them to look for any angles that are vertically opposite, complementary, or supplementary to get them started.

Student Task Statement

Find the unknown angles. Show your thinking. Organise it so it can be followed by others.

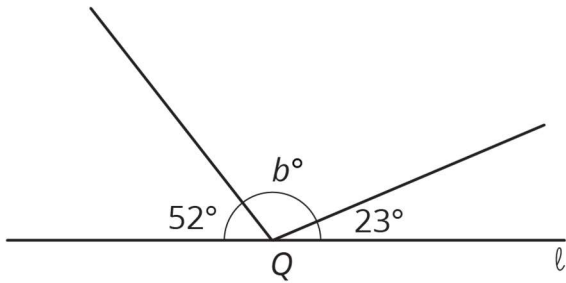
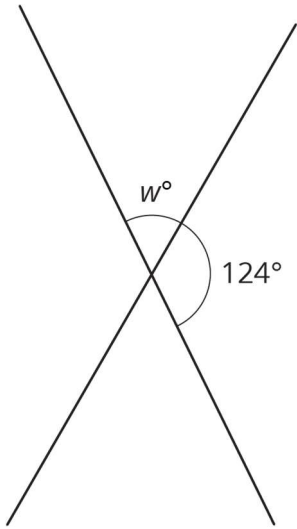

Lines l and m are perpendicular.

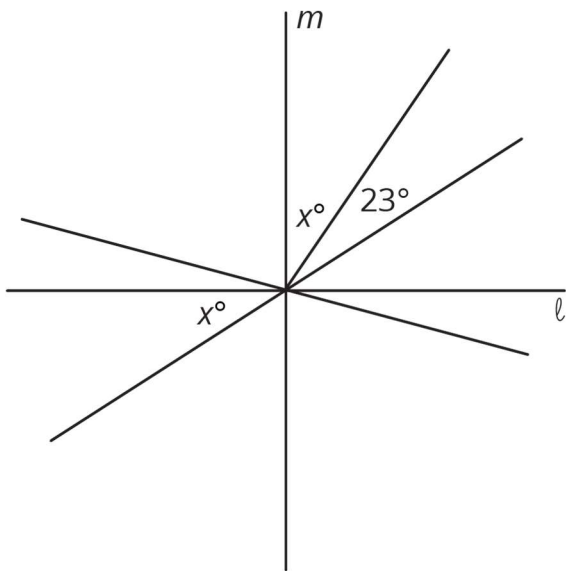

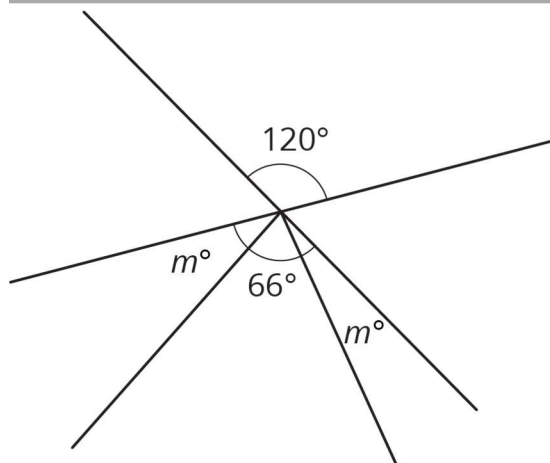

Student Response

- $w = 56$. Sample reasoning: $2(w + 124) = 360$, $w + 124 = 180$, $w = 180 - 124$
- $b = 105$. Sample reasoning: $b + 52 + 23 = 180$, $b = 180 - (52 + 23)$
- $x = 33.5$ or equivalent. Sample reasoning: $2x + 23 = 90$, $2x = 90 - 23$, $x = \frac{1}{2}(90 - 23)$
- $m = 27$. Sample reasoning: $2m + 66 = 120$, $2m = 120 - 66$, $m = \frac{1}{2}(120 - 66)$

Are You Ready for More?

The diagram contains three squares. Three additional line segments have been drawn that connect corners of the squares. We want to find the exact value of $a + b + c$.

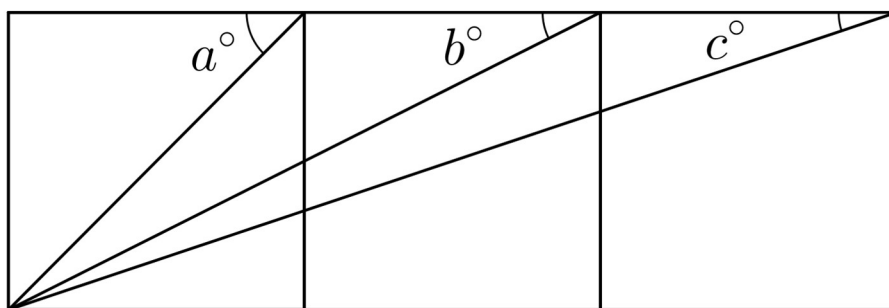

1. Use a protractor to measure the three angles. Use your measurements to conjecture about the value of $a + b + c$.
2. Find the exact value of $a + b + c$ by reasoning about the diagram.

Student Response

$a + b + c = 90$. Measuring carefully with a protractor is convincing, but there are many ways to show that $a + b + c$ is exactly 90° . One way is to expand the diagram with more squares and draw some more line segments. Look at the three adjacent angles with vertices at point K . Angle GKH must equal b because line segment KG spans two squares in the same way CJ does. Just like angle ABC , angle CKG must measure 45° , since triangle CKG is a right-angled triangle.

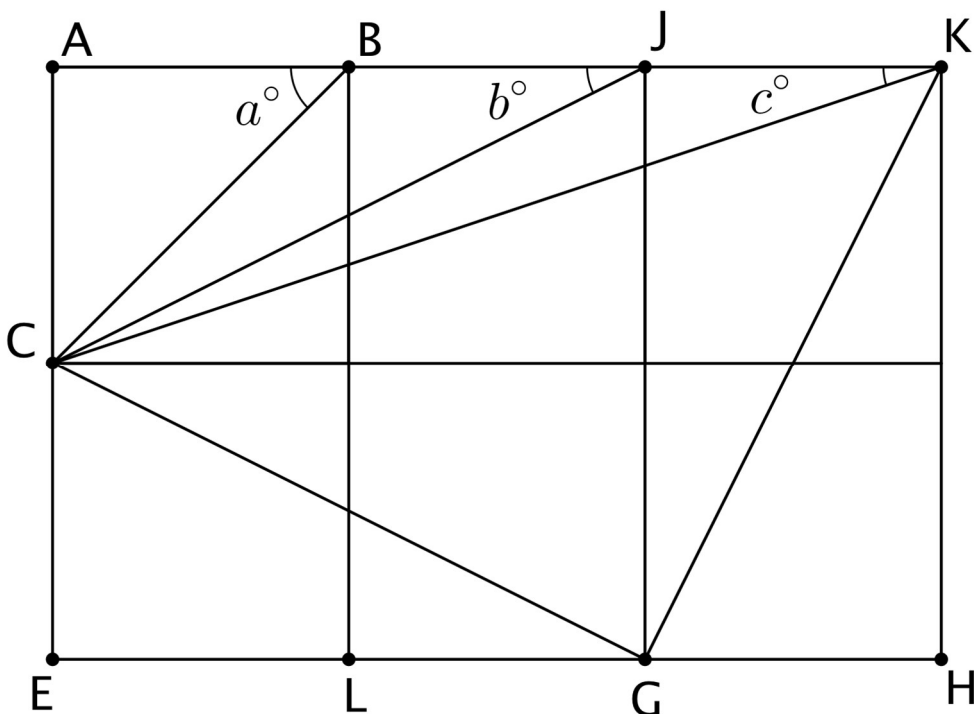

Activity Synthesis

The goal of this discussion is for students to see different equations that can be used to represent and solve for the same unknown angles.

Select students to share their answers to each problem. Consider asking some of the following questions:

- “Did anyone use a different equation for this same problem? If so, did you get the same answer?”
- “Were any of the questions harder than others? Why?”
- “Were there any questions you used a strategy that was new to you?”

Speaking: Discussion Supports. When selected students share how they calculated the angle measurements, invite other students to challenge an idea, elaborate on an idea, or clarify the idea using improved mathematical language. Encourage students to demonstrate

central concepts of the angle relationships (e.g., complementary, supplementary, vertical) multi-modally by explaining their reasoning using images of the angles as well as gestures. This will support student understanding about how to write equations that represent the relationships between angles in a diagram.

Design Principle(s): Optimise output (for explanation); Support sense-making

Lesson Synthesis

- How can equations help us solve for an unknown angle? (They allow us to represent relationships among angles. Then we can solve the equation to find the unknown angles.)
- Is there only one way to solve for an unknown angle? (No, there are usually a few different equations that can be used, based on the relationships present in the diagram.)

5.4 In Words

Cool Down: 5 minutes

Student Task Statement

Here are three intersecting lines.

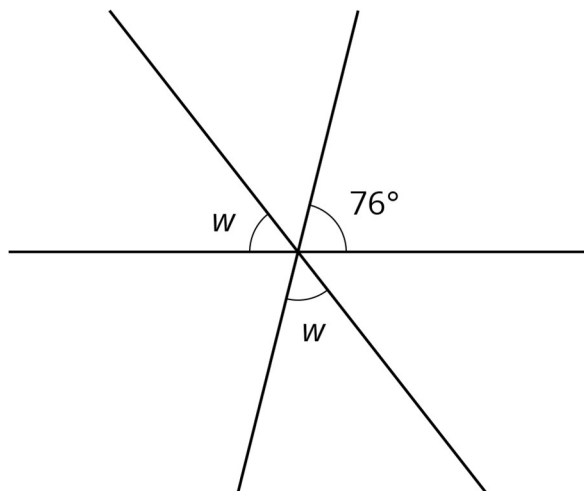

1. Write an equation that represents a relationship between these angles.
2. Describe, in words, the process you would use to find w .

Student Response

1. Answers vary. Samples responses: $2w + 76 = 180$ or $4w + 152 = 360$.
2. Answers vary. Sample responses:
 - Subtract 76 from 180 and then divide by 2 (or multiply by $\frac{1}{2}$).

- Subtract 152 from 360 and then divide by 4 (or multiply by $\frac{1}{4}$).

Student Lesson Summary

To find an unknown angle, sometimes it is helpful to write and solve an equation that represents the situation. For example, suppose we want to know the value of x in this diagram.

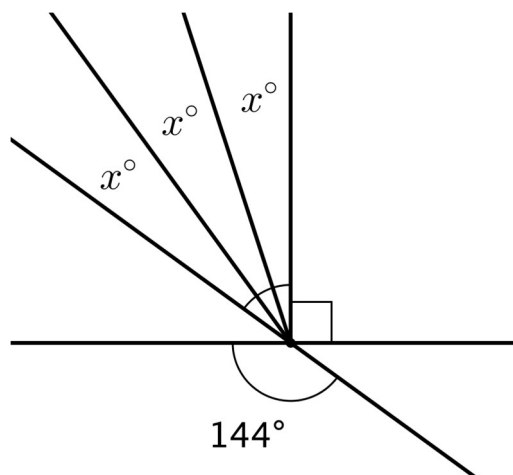

Using what we know about vertically opposite angles, we can write the equation $3x + 90 = 144$ to represent this situation. Then we can solve the equation.

$$\begin{aligned} 3x + 90 &= 144 \\ 3x + 90 - 90 &= 144 - 90 \\ 3x &= 54 \\ 3x \times \frac{1}{3} &= 54 \times \frac{1}{3} \\ x &= 18 \end{aligned}$$

Lesson 5 Practice Problems

1. Problem 1 Statement

Line segments AB , DC , and EC intersect at point C . Angle DCE measures 148° . Find the value of x .

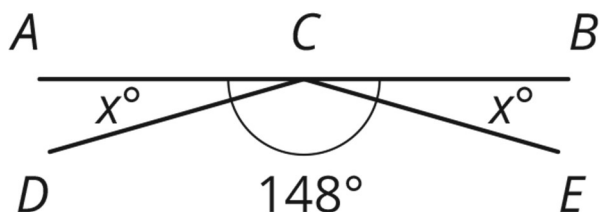

Solution

16

2. Problem 2 Statement

Line ℓ is perpendicular to line m . Find the value of x and w .

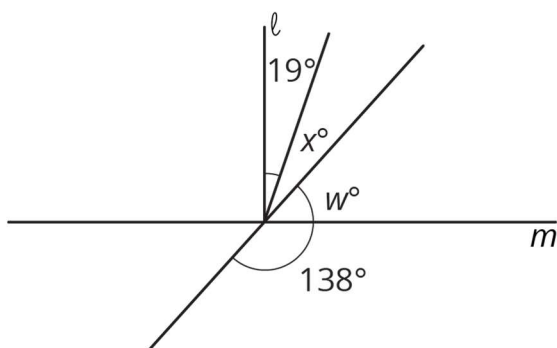

Solution

$$x = 29 \text{ and } w = 42$$

3. Problem 3 Statement

If you knew that two angles were complementary and were given the size of one of those angles, would you be able to find the size of the other angle? Explain your reasoning.

Solution

Yes, because one angle would be known and if two angles are complementary, then the two angles sum to 90° .

4. Problem 4 Statement

For each inequality, decide whether the solution is represented by $x < 4.5$ or $x > 4.5$.

- a. $-24 > -6(x - 0.5)$
- b. $-8x + 6 > -30$
- c. $-2(x + 3.2) < -15.4$

Solution

- a. $x > 4.5$
- b. $x < 4.5$
- c. $x > 4.5$

5. Problem 5 Statement

A runner ran $\frac{2}{3}$ of a 5 kilometre race in 21 minutes. They ran the entire race at a constant speed.

- a. How long did it take to run the entire race?
- b. How many minutes did it take to run 1 kilometre?

Solution

- a. 31.5 minutes
- b. 6.3 minutes

One way to find the answers to both questions is using a ratio table:

distance (km)	time (min)
$\frac{10}{3}$	21
10	63
5	31.5
1	6.3

6. Problem 6 Statement

Jada, Elena, and Lin walked a total of 37 miles last week. Jada walked 4 more miles than Elena, and Lin walked 2 more miles than Jada. The diagram represents this situation:

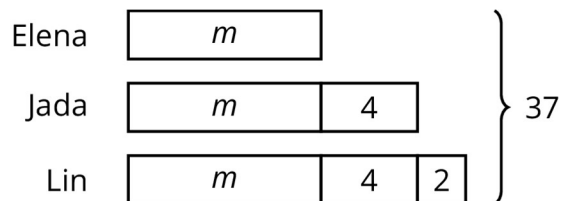

Find the number of miles that they each walked. Explain or show your reasoning.

Solution

Elena: 9 miles, Jada: 13 miles, Lin: 15 miles

Possible strategies:

- $3m + 10 = 37, m = 9$
- Start with the total of 37 miles, subtract 10, and divide by 3

7. Problem 7 Statement

Select **all** the expressions that are equivalent to $-36x + 54y - 90$.

- a. $-9(4x - 6y - 10)$
- b. $-18(2x - 3y + 5)$
- c. $-6(6x + 9y - 15)$
- d. $18(-2x + 3y - 5)$
- e. $-2(18x - 27y + 45)$
- f. $2(-18x + 54y - 90)$

Solution ["B", "D", "E"]



© These materials were derived and adapted from Illustrative Mathematics's IM 6–8 Math™. IM 6–8 Math was originally developed by Open Up Resources and authored by Illustrative Mathematics®, and is copyright 2017–2019 by Open Up Resources. It is licensed under the Creative Commons Attribution 4.0 International License (CC BY 4.0) <https://creativecommons.org/licenses/by/4.0/>. OUR's 6–8 Math Curriculum is available at <https://openupresources.org/math-curriculum/>. Adaptations and updates to IM 6–8 Math™ are copyright 2019 by Illustrative Mathematics®, and are licensed under the Creative Commons Attribution 4.0 International License (CC BY 4.0). Further adaptations have been made by MEI.