

Lesson 11: Slicing solids

Goals

- Categorise images of planes intersecting pyramids and prisms, and describe (orally) the categories.
- Comprehend that the term “cross section” (in spoken and written language) refers to the two-dimensional face that results from slicing a three-dimensional figure.
- Describe, compare, and contrast (orally and in writing) different cross sections that could result from slicing the same pyramid or prism.

Learning Targets

- I can explain that when a three dimensional figure is sliced it creates a face that is two dimensional.
- I can picture different cross sections of prisms and pyramids.

Lesson Narrative

This lesson introduces the idea that slicing a three-dimensional figure with a plane results in a two-dimensional cross section. Slicing a fruit or vegetable, dipping the exposed face in paint, and stamping it on a paper helps students focus on the two-dimensional face that is created by the slice. Given two-dimensional representations of how objects are sliced, students practise visualising the three-dimensional figures and the resulting cross sections.

Addressing

- Describe the two-dimensional figures that result from slicing three-dimensional figures, as in plane sections of cuboids and rectangular-based pyramids.

Building Towards

- Solve real-world and mathematical problems involving area, volume and surface area of two- and three-dimensional objects composed of triangles, quadrilaterals, polygons, cubes, and prisms.

Instructional Routines

- Collect and Display
- Compare and Connect
- Discussion Supports

Required Materials

Fruits or vegetables

Knife

Paint

Blackline Master

Card Sort: Cross Sections, Card A

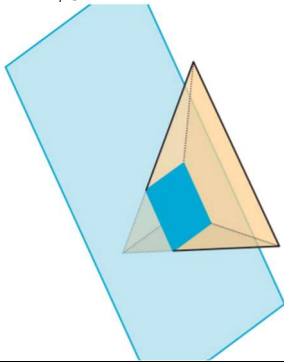

Card Sort: Cross Sections, Card B

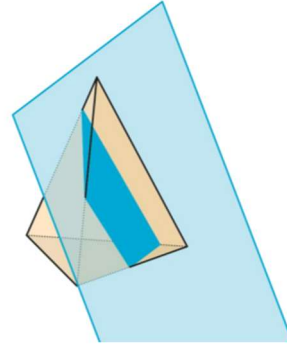

Card Sort: Cross Sections, Card C

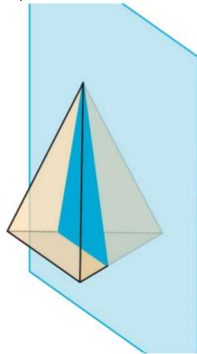

Card Sort: Cross Sections, Card D

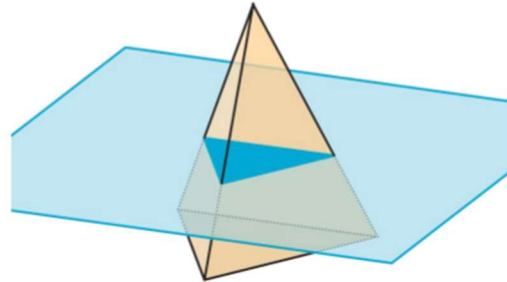

Card Sort: Cross Sections, Card E

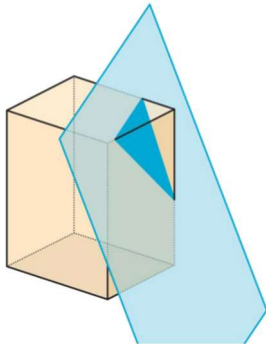

Card Sort: Cross Sections, Card F

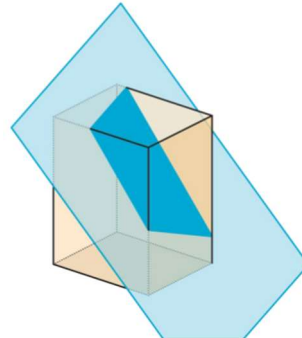

Card Sort: Cross Sections, Card G

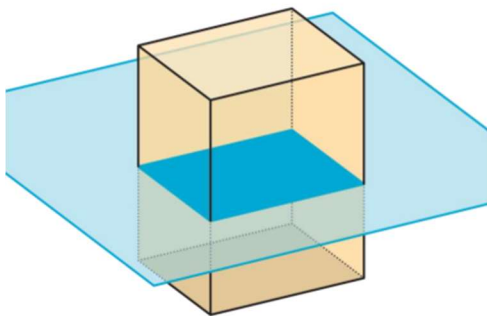

Card Sort: Cross Sections, Card H

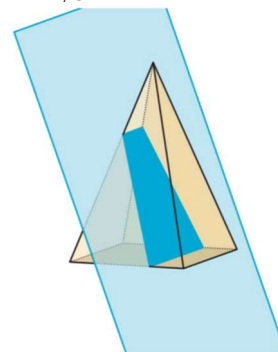

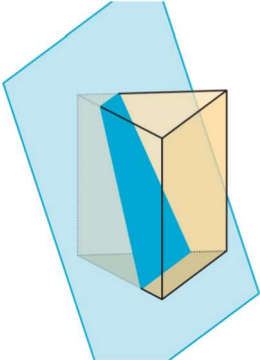
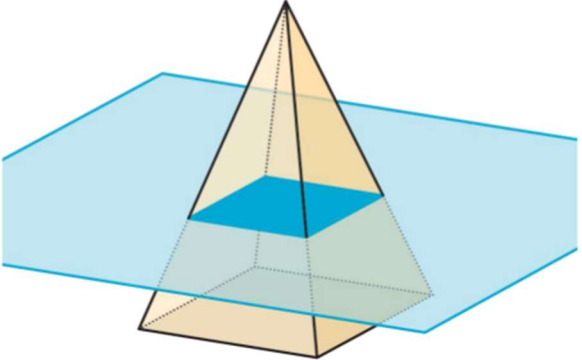
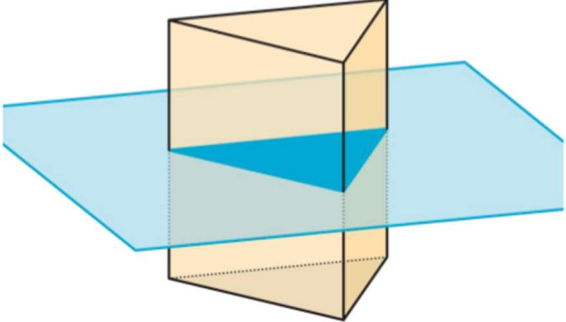
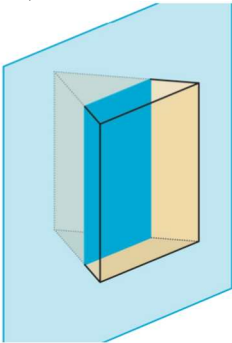
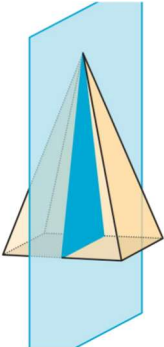
<p>Card Sort: Cross Sections, Card I</p> 	<p>Card Sort: Cross Sections, Card J</p> 
<p>Card Sort: Cross Sections, Card K</p> 	<p>Card Sort: Cross Sections, Card L</p> 
<p>Card Sort: Cross Sections, Card M</p> 	This cell is empty

Required Preparation

As part of the lesson, the teacher will slice a fruit or vegetable to show a cross section. Recommended are apples, potatoes, or carrots. Acrylic paint can also be used to stamp the cross section onto paper. Alternatively, you could purchase a set of solids for which the cross sections can be clearly seen.

You will need the Cross Section Card Sort blackline master for this lesson. Prepare 1 copy per 3 students, cut the slips, and put each set in an envelope. These slips can be reused from one class to the next. If possible, copy each complete set of cards on a different colour of paper, so that a stray card can quickly be put back.

Student Learning Goals

Let's see what shapes you get when you slice a three-dimensional object.

11.1 Prisms, Pyramids, and Polyhedra

Warm Up: 5 minutes (there is a digital version of this activity)

The purpose of this warm-up is to review important characteristics of prisms, pyramids, and polyhedra. Students should be able to interpret the two-dimensional pictures and three-dimensional objects, understanding that the dotted lines indicate hidden lines and identify all of the parts of the polyhedra.

Launch

Ask students, "What do you see? Describe the object and its parts as precisely as you can." Give students 2 minutes of quiet work time followed by a whole-class discussion.

If students have access to digital activities, there is an applet for them to explore while answering the question.

Anticipated Misconceptions

Students may think that a pyramid must have its apex over the centre of the base. Students may think that a prism (or pyramid) must have base at the "bottom".

Student Task Statement

Describe each shape as precisely as you can.

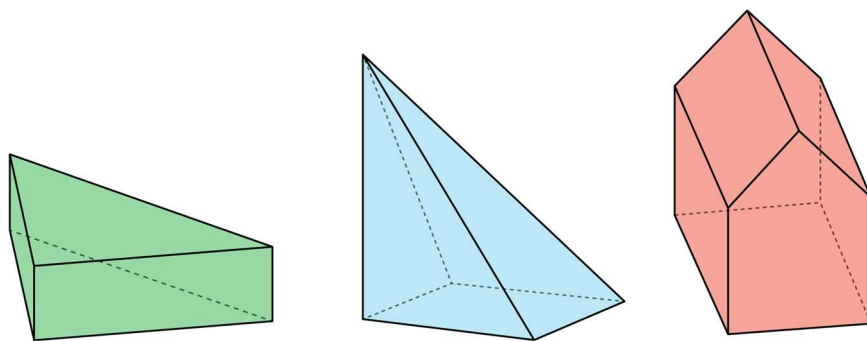

Student Response

The first image is a triangular prism with a base that is a right-angled triangle.

The second image is a rectangular-based pyramid with a vertex that is not centred over the base.

The third image is a prism with a base that is a pentagon.

Activity Synthesis

Ask students to describe each shape. Record and display their responses for all to see. After each student shares, ask the group if they have anything to add before moving on to the next shape.

If not mentioned by students, explain:

- A prism is a polyhedron with two identical polygon bases, connected by rectangles.
- A pyramid is a polyhedron with one polygon base, and all other faces are triangles meeting at a point.

11.2 What's the Cross Section?

10 minutes (there is a digital version of this activity)

The goal of this activity is to help visualise cross sections of a three-dimensional object. One way to do this is to cut a solid object and use one or both of the pieces to stamp the resulting cross section onto paper. This helps students see the two-dimensional shape that results from cutting a three-dimensional object. During the launch of this activity, students see a demonstration of cutting a fruit or vegetable and are asked to describe the shape of the cross section. Students are then asked to describe the shape of a cross section of a three-dimensional object given to them in the task statement.

As students work on the task, monitor for students who can describe the two-dimensional shape produced from each cross section described.

Instructional Routines

- Collect and Display

Launch

Cut the fruit or vegetable so that the cut is in a plane. Some choices: cut an apple vertically, through the stem. (The cross section will be somewhat heart-shaped, with an indentation.) Cut any through the “equator” (The cross section will be a circle.) Carrot or long potato, cut diagonally (The cross section will be an ellipse, oval, or stretched circle.) Before showing students the cut surface, ask students what shape they think the surface is. Then dip the surface into the paint and stamp on a piece of paper. Then put the cut vegetable back together so that both sides of the cut are painted. Show that the resulting pieces each have a cut surface, and the two surfaces are identical.

Display the paper with the painted cross section for all to see. Invite students to describe the shape of the cross section. Tell students that in this activity they are going to have to describe the shape of something after a cut is made. Give students 2–3 minutes of quiet work time followed by time to discuss the shapes with their partner. Follow with a whole-class discussion.

If students *do not* have access to the digital version of the activity, consider projecting the applet and demonstrating for all to see (if possible).

Representation: Develop Language and Symbols. Use virtual or concrete manipulatives to connect symbols to concrete objects or values. Provide students with a printed copy of the student task statement to draw on or annotate.

Supports accessibility for: Conceptual processing Speaking: Collect and Display. As groups discuss, circulate and listen to student talk about the shapes formed when the solids are sliced. Capture student language that reflects a variety of ways students are making sense of the shapes, such as “both cross sections are rectangles” or “the rectangles are not of the same size”. Display the collected language visually for the whole class to use as a reference in further discussions in the lesson and unit. Ask students to suggest revisions, updates, and connections to the display as they develop new mathematical ideas and ways of communicating. This will help students increase awareness of use of mathematical language as they progress through the unit.

Design Principle(s): Support sense-making; Maximise meta-awareness

Anticipated Misconceptions

Some students may struggle to visualise slicing the solids that are shown. It may be helpful to use a three-dimensional model of the cuboid and rectangular-based pyramid to demonstrate where the cut is happening in each question. Building the solids out of salt dough and slicing them with dental floss is another option.

Student Task Statement

Here is a cuboid and a **pyramid** with the same base and same height.

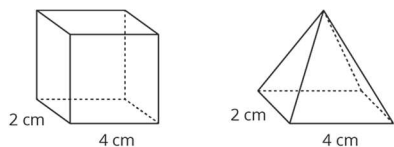

1. Think about slicing each solid parallel to its **base**, halfway up. What shape would each **cross section** be? What is the same about the two cross sections? What is different?
2. Think about slicing each solid parallel to its base, near the top. What shape would each cross section be? What is the same about the two cross sections? What is different?

Student Response

1. Both objects have a cross section in the shape of a rectangle. The difference is that the rectangle on the cuboid is the same size as the base, but the rectangle on the pyramid is smaller.
2. Again, both objects have a cross section in the shape of a rectangle. The rectangle on the cuboid is still the same size as the base, but the rectangle on the pyramid is much smaller.

Are You Ready for More?

Describe the cross sections that would result from slicing each solid perpendicular to its base.

Student Response

Slicing the cuboid perpendicular to its base will always result in a rectangular cross section, regardless of the location of the slice.

Slicing the rectangular pyramid perpendicular to its base could result in a cross section in the shape of a triangle or a trapezium, depending on the location of the slice.

Activity Synthesis

Select previously identified students to describe the shapes of cross sections of the objects. Consider asking some of the following questions:

- “How do the cross sections in the different objects compare to one another?” (One is a scaled copy of the other.)
- “How do the cross sections in each object compare to its own base?” (In the cube, the cross section is the same as the base, in the pyramid, the cross section is a scaled copy of the base.)

Explain to students that in the next activity they will get another chance to determine shapes of different cross sections.

11.3 Card Sort: Cross Sections

10 minutes

In this activity, students practise visualising cross sections in a more abstract way by looking at images of a solid object that has been cut by a plane and matching those images to the shapes created by the cuts. The cuts made in this activity vary from the previous activity in that the cuts are not all parallel to the base of the three-dimensional object.

As students work on the task, monitor for groups of students who use different reasons to sort their cards.

Instructional Routines

- Compare and Connect

Launch

Arrange students into groups of 3. Supply each group with cards cut from the blackline master. Tell students that these cards have different things in common so different groups of students might have different reasons for grouping certain images together. Give students 2–3 minutes of quiet work time followed by a whole-class discussion.

Engagement: Develop Effort and Persistence. Encourage and support opportunities for peer interactions. Invite students to talk about their ideas with a partner before writing them down. Display sentence frames to support students when they explain their strategy. For example, “Both ____ and ____ are alike because . . .”, ____ and ____ are different because . . .”
Supports accessibility for: Language; Social-emotional skills

Student Task Statement

Your teacher will give you a set of cards. Sort the images into groups that make sense to you. Be prepared to explain your reasoning.

Student Response

Answers vary. Sample groupings:

- Cross section is parallel to the base (4 cards), cross section is perpendicular to the base (3 cards), and cross section is oblique to the base (6 cards)
- Cross section is a triangle (5 cards), and cross section is a quadrilateral (8 cards)
- Figure is a cuboid (3 cards), figure is a triangle-based pyramid (4 cards), figure is a square-based pyramid (3 cards), and figure is a triangular prism (3 cards)

Activity Synthesis

Select previously identified groups to share their groupings and reasons for grouping them that way.

If not mentioned by students, explain that there are a few ways to sort the cards:

- Based on the solid object that is being cut. (cuboid, triangular prism, square-based pyramid, triangle based pyramid)
- Based on the cross section made by the cuts. (parallel to the base, perpendicular to the base, oblique to the base)
- Based on the shape of cross section. Note that there could be two or three groups for these cards: triangles, and quadrilaterals or triangles, rectangles, and trapeziums.

Explain to students that it is possible to create other cross section shapes by cutting these objects in other ways.

Listening, Speaking, Conversing: Compare and Connect. After students have sorted the images into groups that make sense to them, ask students to investigate each other’s work by taking a tour of their visual displays. Facilitate discussion among students by asking questions such as, “What similarities or differences do you see in other groups’ sorting as compared to your sorting?” or “What worked well while sorting the images?” Guide students to make connections between specific features of the images, such as the shape of a cross section and the cross section made by the cuts. This will help foster students’ meta-

awareness of the language as they compare or contrast the sorting of images.

Design Principle(s): Cultivate conversation; Maximise meta-awareness

11.4 Drawing Cross Sections

Optional: 20 minutes (there is a digital version of this activity)

In this activity, students are given pictures and descriptions of planes cutting prisms and pyramids. Students are asked to draw cross sections freehand but this is not a skill that is required in order for students to be able to describe two-dimensional shapes created from cross sections, which is why this is an optional activity. Some pictures are of a moving plane. Students describe how the cross section changes as the plane moves.

If students have access to the digital activity there are applets to explore the cross sections.

Adapted from applets created in GeoGebra by [Anthony C.M. OR](#).

Instructional Routines

- Discussion Supports

Launch

Arrange students in groups of 2. Give students 3–5 minutes of quiet work time followed by time to discuss shapes of cross sections with a partner. Follow with a whole-class discussion.

Student Task Statement

Draw and describe each cross section.

1. Here is a picture of a cuboid, 4 units by 2 units by 3 units.

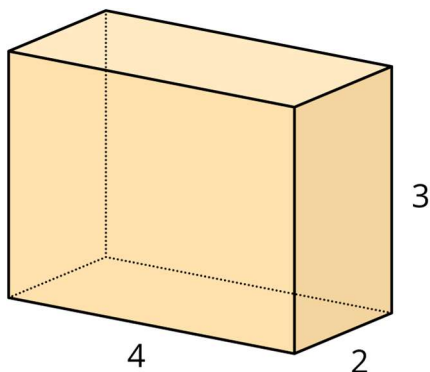

- a. A plane cuts the prism parallel to the bottom and top faces.
-

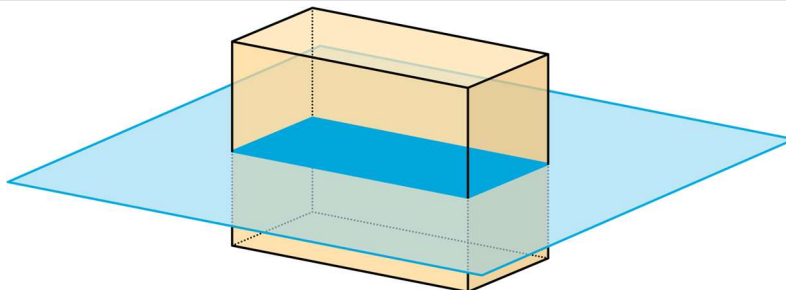

- b. The plane moves up and cuts the prism at a different height.

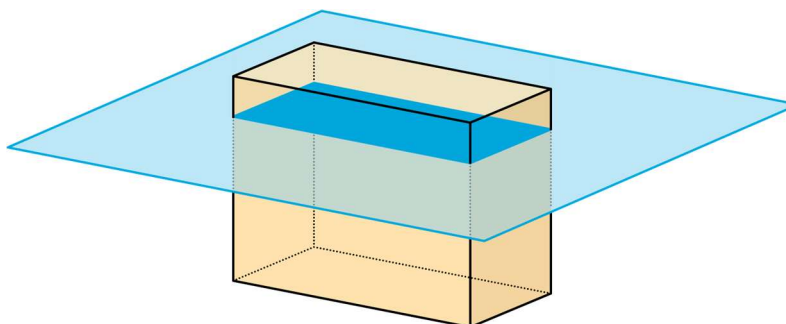

- c. A vertical plane cuts the prism diagonally.

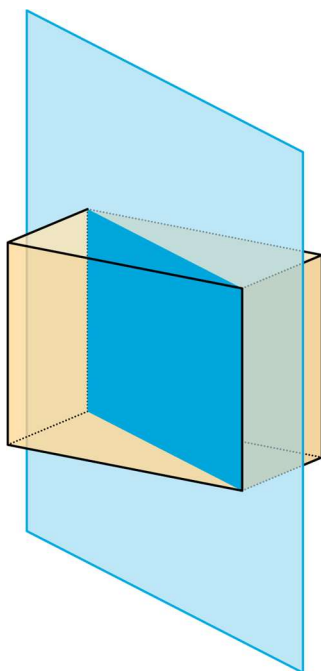

2. A square-based pyramid has a base that is 4 units by 4 units. Its height is also 4 units.
- a. A plane cuts the pyramid parallel to the base.

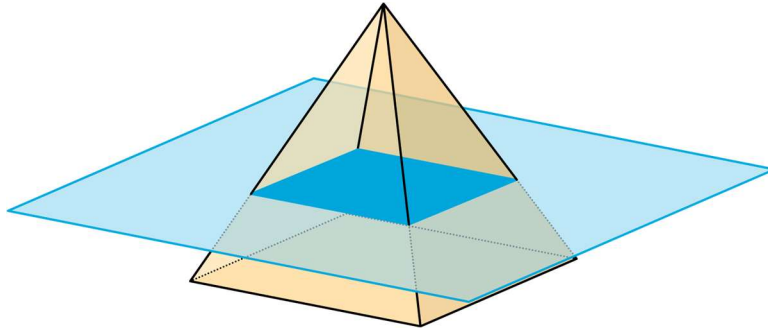

b. A vertical plane cuts the prism.

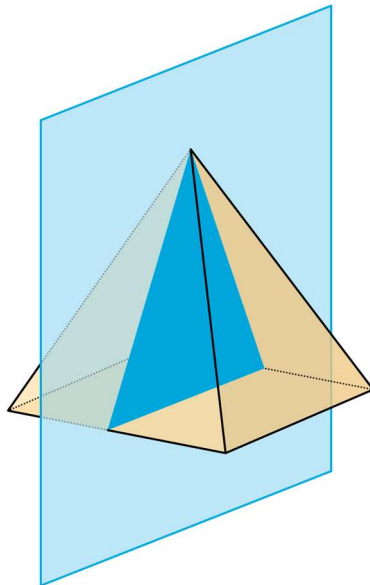

3. A cube has an edge of length 4.

a. A plane cuts off the corner of the cube.

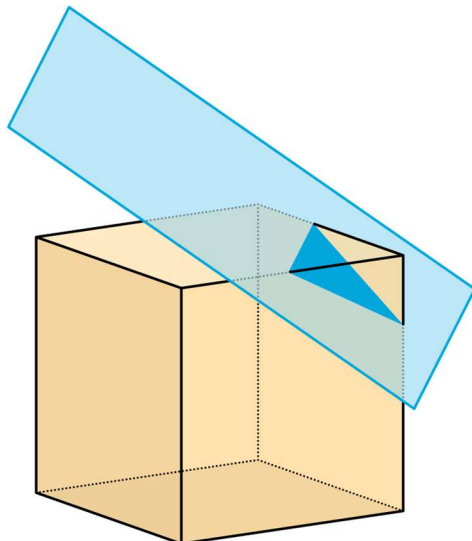

- b. The plane moves further from the corner and makes a cut through the middle of the cube.

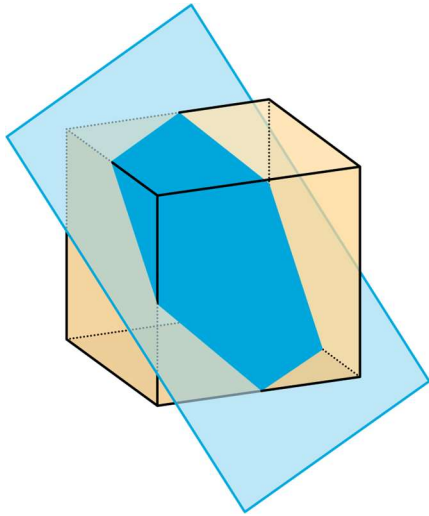

Student Response

Drawings of:

- a. A rectangle with length 4 and width 2.
- b. A rectangle with length 4 and width 2.
- c. A rectangle with height 3 and width the length of the diagonal of the base.
- a. A square with width and length less than 4.
- b. An isosceles triangle with base 4 and height 4.
- a. A triangle.
- b. A hexagon.

Activity Synthesis

Select students to share their drawings and descriptions. Consider asking some of the following questions:

- “How did you figure out the shape of the cross section?”
- “What helped you visualise the shape?”
- “Were any of the shapes you drew here similar to the shapes you described in the previous activity?”

Conversing: Discussion Supports. To support a rich discussion while students are describing two-dimensional shapes created from cross sections, invite students to include details in

their descriptions and drawings of each cross section. Provide sentence frames such as: “The cross section is ___ because . . .”, “A plane cuts ___ as shown by . . .”, or “The dimensions of a cross section are ___ since . . .” This will help students make sense of complex language as they draw and describe cross sections shown in each figure.

Design Principle(s): Cultivate conversation

Lesson Synthesis

- “What is a cross section?” (It is a two-dimensional shape that results from slicing a three-dimensional object.)
- “What are the possible cross sections that can result from a prism that is sliced parallel to its base?” (All cross sections will be the same size and shape as the base.)
- “Can cross sections of a prism or pyramid be a different shape than the base? Explain or give an example.” (Yes, they can be different. For example, slicing off the corner of a cube can result in a triangle.)

11.5 Pentagonal Pyramid

Cool Down: 5 minutes

Student Task Statement

Here is a pyramid with a base that is a pentagon with all sides the same length.

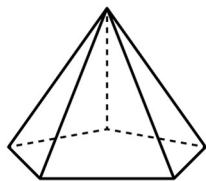

1. Describe the cross section that will result if the pyramid is sliced:
 - a. horizontally (parallel to the base).
 - b. vertically through the top vertex (perpendicular to the base).
2. Describe another way you could slice the pyramid that would result in a different cross section.

Student Response

1. Cross sections:
 - a. A pentagon with all sides the same length, but smaller than the base of the pyramid
 - b. A triangle
 2. Answers vary. Sample responses:
-

- a. You could slice the pyramid diagonally.
- b. You could slice the pyramid vertically but not through the top vertex.

Student Lesson Summary

When we slice a three-dimensional object, we expose new faces that are two dimensional. The two-dimensional face is a **cross section**. Many different cross sections are possible when slicing the same three-dimensional object.

Here are two peppers. One is sliced horizontally, and the other is sliced vertically, producing different cross sections.



The imprints of the slices represent the two-dimensional faces created by each slice.

It takes practice imagining what the cross section of a three-dimensional object will be for different slices. It helps to experiment and see for yourself what happens!

Glossary

- base (of a prism or pyramid)
- cross section
- prism
- pyramid

Lesson 11 Practice Problems

1. Problem 1 Statement

A cube is cut into two pieces by a single slice that passes through points A , B , and C . What shape is the cross section?

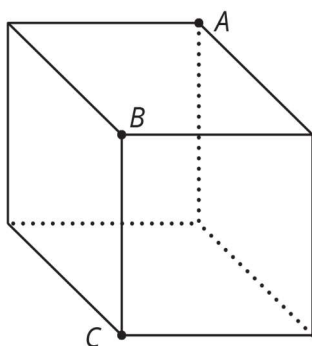

Solution

Rectangle

2. Problem 2 Statement

Describe how to slice the three-dimensional figure to result in each cross section.

Three-dimensional figure:

Cross sections:

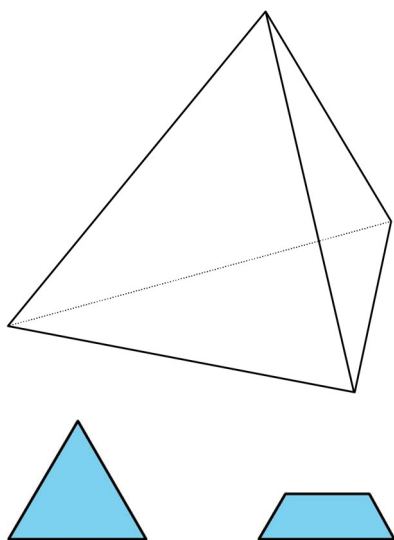

Solution

To get a cross section that is a triangle, make a slice that is parallel to one of the pyramid's faces. To get a cross section that is a trapezium, make a slice that is perpendicular to one of the pyramid's faces that does not pass through the pyramid's opposite vertex.

3. Problem 3 Statement

Here are two three-dimensional figures.

A

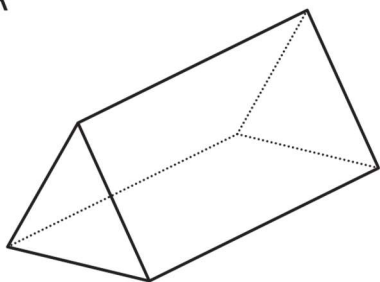

B

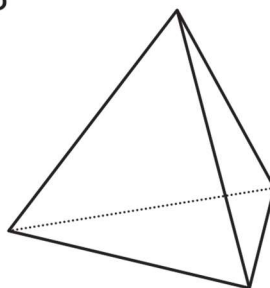

Describe a way to slice one of the figures so that the cross section is a rectangle.

Solution

If you slice figure A perpendicular to its triangular bases, the cross section is a rectangle.

4. Problem 4 Statement

Each row contains the degree measures of two supplementary angles. Complete the table.

size of an angle	size of its supplement
80°	
25°	
119°	
x	

Solution

size of an angle	size of its supplement
80°	100°
25°	155°
119°	61°
x	$180 - x$

5. Problem 5 Statement

Two months ago, the price, in pounds, of a mobile phone was c .

- Last month, the price of the phone increased by 10%. Write an expression for the price of the phone last month.
- This month, the price of the phone decreased by 10%. Write an expression for the price of the phone this month.
- Is the price of the phone this month the same as it was two months ago? Explain your reasoning.

Solution

- $1.1c$ or equivalent (Because 10% of c is $0.1c$ and, adding this to c , gives $1.1c$)
- $0.99c$ or equivalent (Because 10% of $1.1c$ is $0.11c$ and this gives $0.99c$ when subtracted from $1.1c$)

- c. No, the phone is a little bit cheaper now than it was a month ago. The 10% discount this month is on the higher price so it is more than the 10% increase a month ago.



© These materials were derived and adapted from Illustrative Mathematics's IM 6–8 Math™. IM 6–8 Math was originally developed by Open Up Resources and authored by Illustrative Mathematics®, and is copyright 2017–2019 by Open Up Resources. It is licensed under the Creative Commons Attribution 4.0 International License (CC BY 4.0) <https://creativecommons.org/licenses/by/4.0/>. OUR's 6–8 Math Curriculum is available at <https://openupresources.org/math-curriculum/>. Adaptations and updates to IM 6–8 Math™ are copyright 2019 by Illustrative Mathematics®, and are licensed under the Creative Commons Attribution 4.0 International License (CC BY 4.0). Further adaptations have been made by MEI.