

Lesson 5: Bases and heights of parallelograms

Goals

- Comprehend the terms “base” and “height” to refer to one side of a parallelogram and the perpendicular distance between that side and the opposite side.
- Generalise (orally) a process for finding the area of a parallelogram, using the length of a base and the corresponding height.
- Identify a base and the corresponding height for a parallelogram, and understand that there are two different base-height pairs for any parallelogram.

Learning Targets

- I can identify pairs of base and height of a parallelogram.
- I can write and explain the formula for the area of a parallelogram.
- I know what the terms "base" and "height" refer to in a parallelogram.

Lesson Narrative

Students begin this lesson by comparing two strategies for finding the area of a parallelogram. This comparison sets the stage both for formally defining the terms **base** and **height** and for writing a general formula for the area of a parallelogram. Being able to correctly identify a base-height pair for a parallelogram requires looking for and making use of structure.

The terms **base** and **height** are potentially confusing because they are sometimes used to refer to particular line segments, and sometimes to the length of a line segment or the distance between parallel lines. Furthermore, there are always two base-height pairs for any parallelogram, so asking for *the* base and *the* height is not, technically, a well-posed question. Instead, asking for *a* base and its corresponding height is more appropriate. As students clarify their intended meaning when using these terms, they are attending to precision of language. In these materials, the words “base” and “height” mean the numbers unless it is clear from the context that it means a segment and that there is no potential confusion.

By the end of the lesson, students both look for a pattern they can generalise to the formula for the area of a rectangle and make arguments that explain why this works for all parallelograms.

Addressing

- Write expressions that record operations with numbers and with letters standing for numbers. For example, express the calculation “Subtract y from 5” as $5 - y$.
- Evaluate expressions at specific values of their variables. Include expressions that arise from formulas used in real-world problems. Perform arithmetic operations,

including those involving whole-number exponents, in the conventional order when there are no brackets to specify a particular order (Order of Operations). For example, use the formulas $V = s^3$ and $A = 6s^2$ to find the volume and surface area of a cube with sides of length $s = \frac{1}{2}$.

- Find the area of right-angled triangles, other triangles, special quadrilaterals, and polygons by composing into rectangles or decomposing into triangles and other shapes; apply these techniques in the context of solving real-world and mathematical problems.

Instructional Routines

- Compare and Connect
- Discussion Supports
- Notice and Wonder
- Think Pair Share

Required Materials

Geometry toolkits

tracing paper, graph paper, coloured pencils, scissors, and an index card to use as a straightedge or to mark right angles.

Student Learning Goals

Let's investigate the area of parallelograms some more.

5.1 A Parallelogram and Its Rectangles

Warm Up: 10 minutes (there is a digital version of this activity)

In this warm-up, students compare and contrast two ways of decomposing and rearranging a parallelogram on a grid such that its area can be found. It serves a few purposes: to reinforce the work done in the previous lesson; to allow students to practise communicating their observations; and to shed light on the features of a parallelogram that are useful for finding area—a base and a corresponding height.

The flow of key ideas—to be uncovered during discussion and gradually throughout the lesson—is as follows:

- There are multiple ways to decompose a parallelogram (with one cut) and rearrange it into a rectangle whose area we can determine.
 - The cut can be made in different places, but to compose a rectangle, the cut has to be at a *right angle* to two opposite sides of the parallelogram.
 - The length of one side of this newly composed rectangle is the same as the length of one side of the parallelogram. We use the term **base** to refer to this side.
-

- The length of the other side of the rectangle is the length of the cut we made to the parallelogram. We call this segment a **height** that corresponds to the chosen base.
- We use these two lengths to determine the area of the rectangle, and thus also the area of the parallelogram.

As students work and discuss, identify those who make comparisons in terms of the first two points so they could share later. Be sure to leave enough time to discuss the first four points as a class.

Instructional Routines

- Think Pair Share

Launch

Arrange students in groups of 2. Give students 2 minutes of quiet think time and access to geometry toolkits. Ask them to share their responses with a partner afterwards.

If using the digital activity, have students explore the applet for 3 minutes individually, and then discuss with a partner. Students will be able to see the cuts by dragging the point on the segment under the parallelogram.

Student Task Statement

Elena and Tyler were finding the area of this parallelogram:

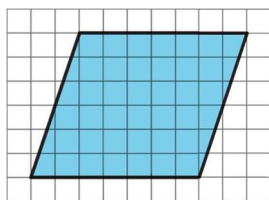

Here is how Elena did it:

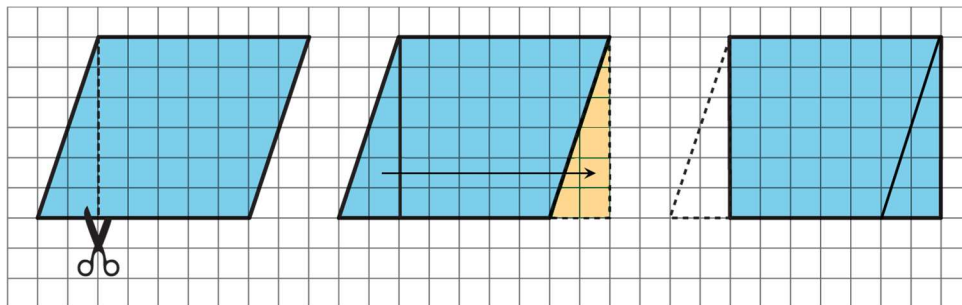

Here is how Tyler did it:

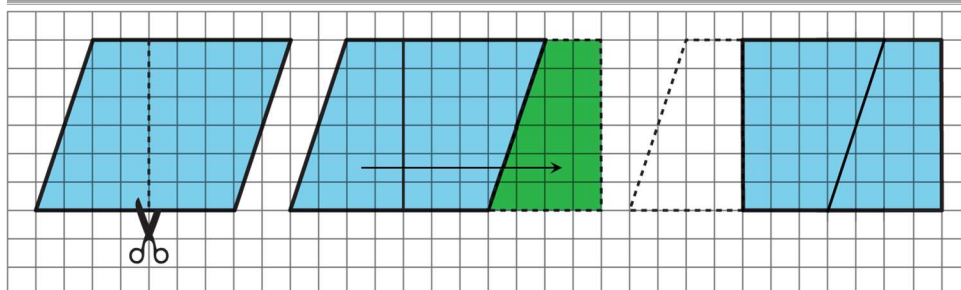

How are the two strategies for finding the area of a parallelogram the same? How they are different?

Student Response

Answers vary. Sample responses:

- Similar: They both cut off a piece from the left of the parallelogram and moved it over to the right to make a rectangle. The rectangles they made are identical.
- Different: They cut the parallelogram at different places. Elena cut a right-angled triangle from the left side and Tyler cut off a trapezium. The rectangles they made are not in the same place.

Activity Synthesis

Ask a few students to share what was the same and what was different about the methods they observed.

Highlight the following points on how Elena and Tyler's approaches are the same, though do not expect students to use the language. Instead, rely on pointing and gesturing to make clear what is meant. If any of these are not mentioned by the students, share them.

- The rectangles are identical; they have the same side lengths. (Label the side lengths of the rectangles.)
- The cuts were made in different places, but the length of the cuts was the same. (Label the lengths along the vertical cuts.)
- The horizontal sides of the parallelogram have the same length as the horizontal sides of the rectangle. (Point out how both segments have the same length.)
- The length of each cut is also the distance between the two horizontal sides of the parallelogram. It is also the vertical side length of the rectangle. (Point out how that distance stays the same across the horizontal length of the parallelogram.)

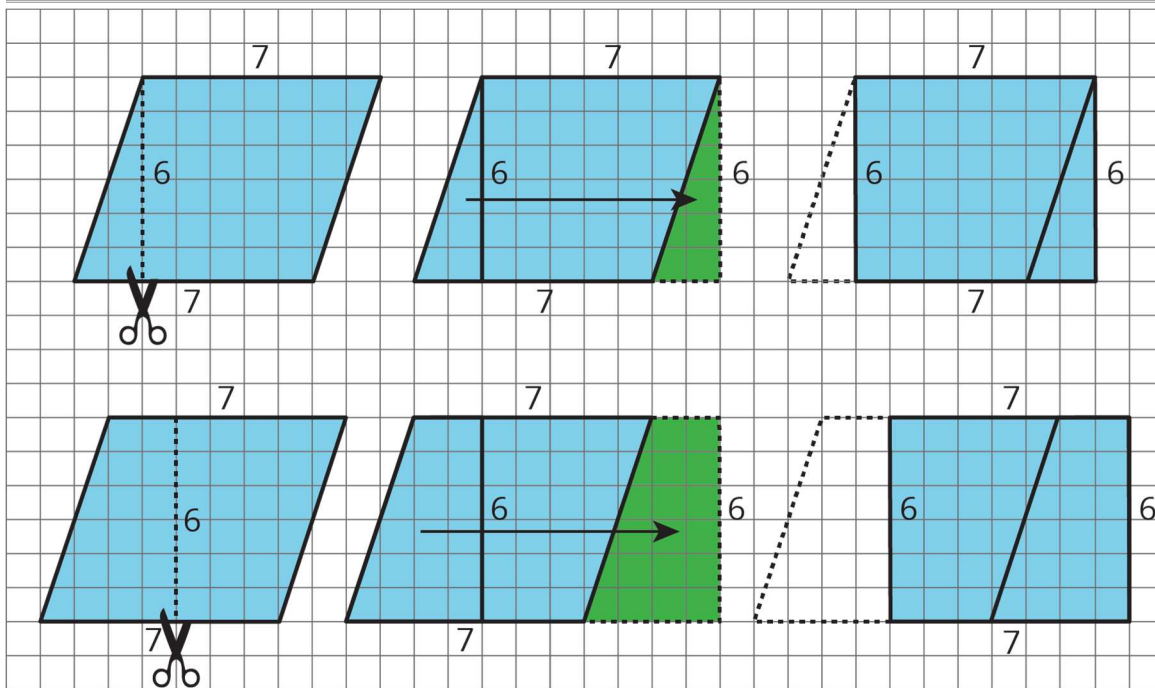

Begin to connect the observations to the terms **base** and **height**. For example, explain:

- “The two measurements that we see here have special names. The length of one side of the parallelogram—which is also the length of one side of the rectangle—is called a *base*. The length of the vertical cut segment—which is also the length of the vertical side of the rectangle—is called a *height* that corresponds to that base.”
- “Here, the side of the parallelogram that is 7 units long is also called a base. In other words, the word *base* is used for both the segment and the measurement.”

Tell students that we will explore bases and heights of a parallelogram in this lesson.

5.2 The Right Height?

20 minutes (there is a digital version of this activity)

Previously, students saw numerical examples of a base and a height of a parallelogram. This activity further develops the idea of base and height through examples and non-examples and error analysis.

Some important ideas to be uncovered here:

- In a parallelogram, the term “base” refers to the length of one side and “height” to the length of a perpendicular segment between that side and the opposite side.
- Any side of a parallelogram can be a base.
- There are always two base-height pairs for a given parallelogram.

Instructional Routines

- Discussion Supports
- Notice and Wonder
- Think Pair Share

Launch

Display the image of examples and non-examples of bases and heights for all to see. Read aloud the description for examples and non-examples. Give students a minute to observe it and to prepare to share at least one thing they notice and one thing they wonder about. When the minute is up, invite students to share their responses with the class, and record these for all to see. It isn't necessary to address their questions at this time.

Students may notice:

- Both sets of diagrams show the same 2 pairs of parallelograms and the same sides labelled "base."
- All the examples show a right-angle mark, a dashed segment, and a side labelled "base."
- Only one of the non-examples show a right-angle mark, but all of them show a dashed segment.
- In both examples and non-examples, there is one parallelogram with a dashed segment and a right angle shown outside of it.
- If the dashed segments are used to cut the first three parallelograms in the examples, the cut-out pieces could be rearranged to form a rectangle. The same cannot be done for the dashed segments in the non-examples.

They may wonder:

- why some dashed segments are inside the parallelogram and some are outside.
- what the rule might be for a dashed segment to be considered a height.
- what the bases and heights have to do with area.

Arrange students in groups of 2. Give students 4–5 minutes to complete the first question with their partner. Ask them to pause for a class discussion after the first question. Select a student or a group to make a case for whether each statement is true or false. If one or more students disagree, ask them to explain their reasoning and discuss to reach a consensus. Before moving on to the next question, be sure students record the verified true statements so that they can be used as a reference later.

Give students 3–4 minutes of quiet time to answer the second question and another 2–3 minutes to share their responses with a partner. Ask them to focus partner conversations on the following questions, displayed for all to see:

- How do you know the parallelogram is labelled correctly or incorrectly?
- Is there another way a base and height could be labelled on this parallelogram?

After answering the questions, students using the digital activity can explore the applet ggbm.at/UnfbrN96 and use it to verify their responses and further their understanding of bases and heights. The applet is a dynamic parallelogram with a height displayed. It allows students to see placements of height in a variety of parallelograms and when any side is chosen as a base.

Listening, Speaking, Conversing: Discussion Supports. As students share their responses with a partner, invite them to restate each other's reasoning using the terms base, height, and perpendicular. If needed, demonstrate the meaning of perpendicular multi-modally using manipulatives, drawings, and gestures. Encourage students to challenge each other when they disagree, using prompts such as "I agree because . . ." or "I disagree because . . ."

Design Principle(s): Support sense-making

Anticipated Misconceptions

Students may not yet internalise that any side of parallelogram can be a base (they may think that a base must be the bottom, horizontal side), or that the height needs to be perpendicular to the base. Point out where the right angle symbols are located and how they relate to the height. Students may think a segment showing the height cannot be drawn outside of the parallelogram (as in parallelogram C).

Students may relate how they think about the side lengths of a rectangle and inaccurately apply it to parallelogram E.

Student Task Statement

Study the examples and non-examples of **bases** and **heights** of parallelograms.

- Examples: The dashed segments in these drawings represent the corresponding height for the given base.

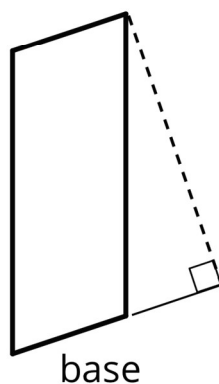
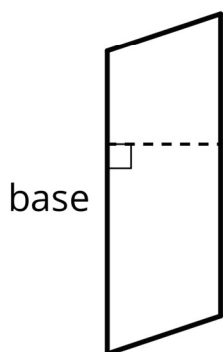
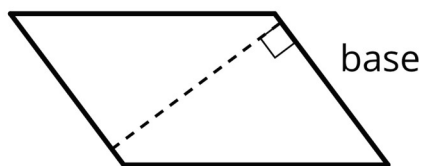
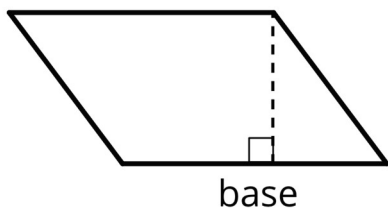

- Non-examples: The dashed segments in these drawings do *not* represent the corresponding height for the given base.

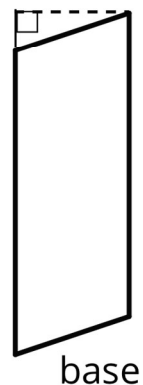
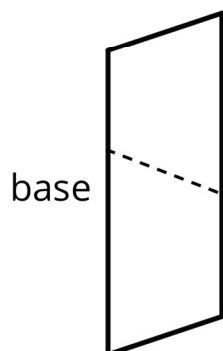
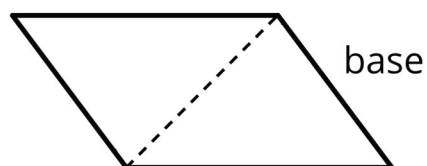
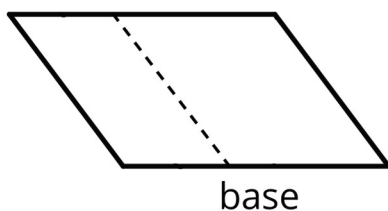

1. Select **all** the statements that are true about bases and heights in a parallelogram.
 - a. Only a horizontal side of a parallelogram can be a base.

- b. Any side of a parallelogram can be a base.
 - c. A height can be drawn at any angle to the side chosen as the base.
 - d. A base and its corresponding height must be perpendicular to each other.
 - e. A height can only be drawn inside a parallelogram.
 - f. A height can be drawn outside of the parallelogram, as long as it is drawn at a 90-degree angle to the base.
 - g. A base cannot be extended to meet a height.
2. Five students labelled a base b and a corresponding height h for each of these parallelograms. Are all drawings correctly labelled? Explain how you know.

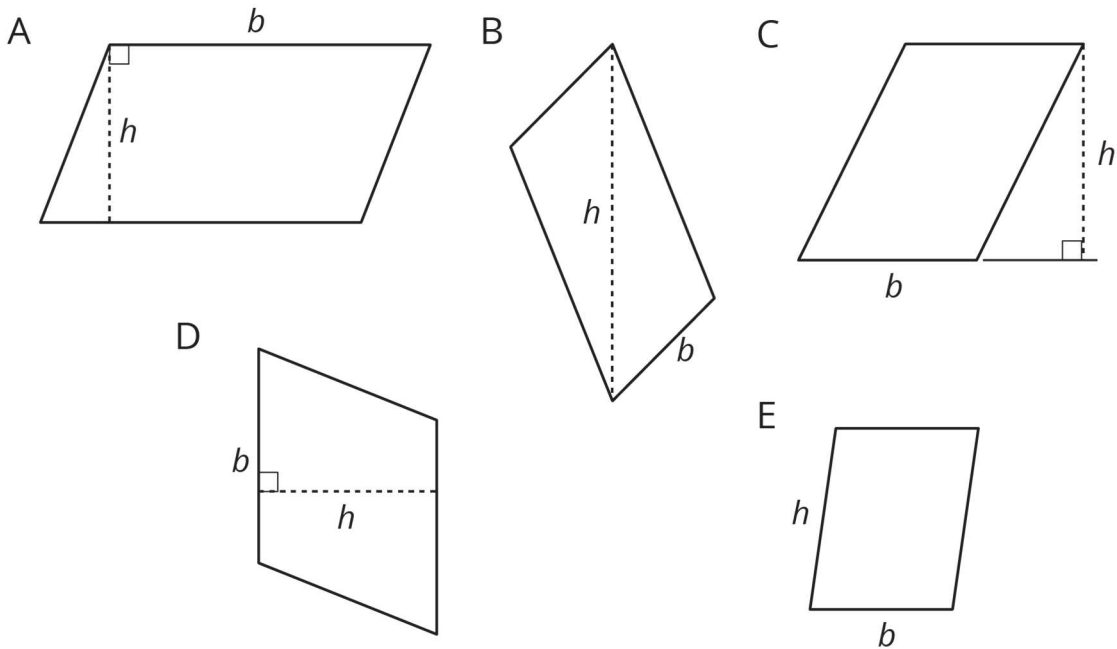

Student Response

1. Statements B, D, and F are true.
2. A, C, and D are correct. B and E are not correct because in each, the segment labelled with an h is not perpendicular to the side labelled with a b .

Activity Synthesis

Poll the class—with a quick agree-or-disagree signal—on whether each figure in the last question is labelled correctly with b and h . After each polling, ask a student to explain how they know it is correct or incorrect.

If a parallelogram is incorrectly labelled, ask where a correct height could be. If it is correctly labelled, ask students if there is another base and height that could be labelled on

this parallelogram. Be sure students understand which parallelograms are labelled correctly before moving forward in this lesson.

An important point to emphasise: “We can choose any side of a parallelogram as a base. To find the height that corresponds to that base, draw a segment that joins the base and its opposite side; that segment has to be perpendicular to both.”

Consider using the applet ggbm.at/UnfbrN96 to further illustrate possible base-height pairs and reinforce students' understanding of them.

5.3 Finding the Formula for Area of Parallelograms

15 minutes

In previous lessons, students reasoned about the area of parallelograms by decomposing, rearranging, and enclosing them and by using what they know about the area of rectangles. They also identified base-height pairs in parallelograms. Here, they use what they learned to find the area of new parallelograms, generalise the process, and write an expression for finding the area of any parallelogram.

As students discuss their work, monitor conversations for any disagreements between partners. Support them by asking clarifying questions:

- “How did you choose a base? How can you be sure that is the height?”
- “How did you find the area? Why did you choose that strategy for this parallelogram?”
- “Is there another way to find the area and to check our answer?”

Instructional Routines

- Compare and Connect
- Think Pair Share

Launch

Keep students in groups of 2. Give students access to their geometry toolkits and 5–7 minutes of quiet think time to complete the first four rows of the table. Ask them to be prepared to share their reasoning. If time is limited, consider splitting up the work: have one partner work independently on parallelograms A and C, and the other partner on B and D. Encourage students to use their work from earlier activities (on bases and heights) as a reference.

Ask students to pause after completing the first four rows and to share their responses with their partner. Then, they should discuss how to write the expression for the area of any parallelogram. Students should notice that the area of every parallelogram is the product of a base and its corresponding height.

Representation: Internalise Comprehension. Demonstrate and encourage students to use colour coding and annotations to highlight connections between representations in a

problem. As students describe their thinking, highlight the base-height pairs on each parallelogram and record the responses in the table.

Supports accessibility for: Visual-spatial processing; Conceptual processing

Anticipated Misconceptions

Finding a height segment outside of the parallelogram may still be a rather unfamiliar idea to students. Have examples from the “The Right Height?” section visible so they can serve as a reference in finding heights.

Students may say that the base of parallelogram D cannot be determined because, as displayed, it does not have a horizontal side. Remind students that in an earlier activity we learned that any side of a parallelogram could be a base. Ask students to see if there is a side whose length can be determined.

Student Task Statement

For each parallelogram:

- Identify a base and a corresponding height, and record their lengths in the table.
- Find the area of the parallelogram and record it in the last column of the table.

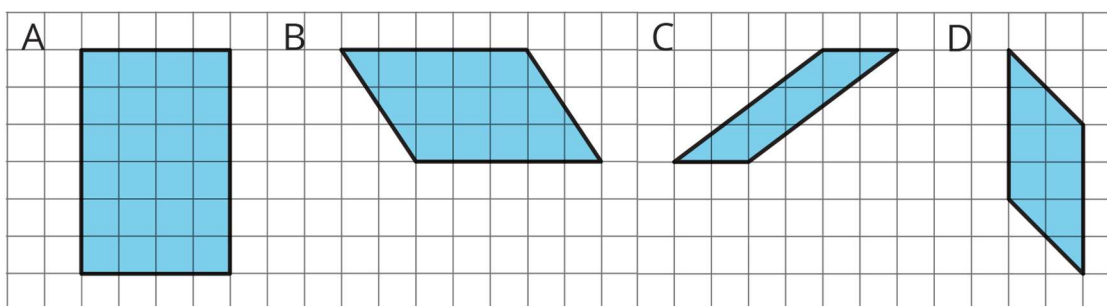

parallelogram	base (units)	height (units)	area (sq units)
A			
B			
C			
D			
any parallelogram	b	h	

In the last row, write an expression for the area of any parallelogram, using b and h .

Student Response

While there are two possible base-height pairs, these are the easiest ones for students to use given the orientation of each parallelogram on the grid.

parallelogram	base (units)	height (units)	area (square units)
A	6 (or 4)	4 (or 6)	24
B	5	3	15
C	2	3	6
D	4	2	8
any parallelogram	b	h	$b \times h$

Are You Ready for More?

1. What happens to the area of a parallelogram if the height doubles but the base is unchanged? If the height triples? If the height is 100 times the original?
2. What happens to the area if both the base and the height double? Both triple? Both are 100 times their original lengths?

Student Response

1. The area doubles, triples, is multiplied by 100.
2. The area quadruples, is 9 times the original area, is 10 000 times the original area.

Activity Synthesis

Display the parallelograms and the table for all to see. Select a few students to share the correct answers for each parallelogram. As students share, highlight the base-height pairs on each parallelogram and record the responses in the table. Although only one base-height pair is named for each parallelogram, reiterate that there is another pair. Show the second pair on the diagram or ask students to point it out.

After all answers for the first four rows are shared, discuss the following questions, displayed for all to see:

- “How did you determine the expression for the area for any parallelogram?” (The areas of parallelograms A–D are each the product of base and height.)
- “Suppose you decompose a parallelogram with a cut and rearrange it into a rectangle. Does this expression for finding area still work? Why or why not?” (Yes. One side of the rectangle will be the same as the base of the parallelogram. The height of the parallelogram is also the height of the rectangle—both are perpendicular to the base.)
- “Do you think this expression will always work?”

Be sure everyone has the correct expression for finding the area of a parallelogram by the end of the discussion. The second discussion question is meant to elicit connections to the parallelogram’s related rectangle as they decomposed and rearranged to find the area. The third question (about whether the expression will always work) is not meant to be proven here, so speculation on students’ part is expected at this point. It is intended to prompt students to think of other differently-shaped parallelograms beyond the four shown here.

Representing, Conversing: Compare and Connect. When students share their responses for the first four rows of the table, ask students to identify what is the same and what is different about how they determined the base and height for each parallelogram. Listen for and amplify student discussions that attempt to explain why their different approaches led to the same area. Then ask students if any side of a parallelogram can be used as the base. This will help students understand how the area of every parallelogram is product of the base and its corresponding height.

Design Principle(s): Support sense-making

Lesson Synthesis

In this lesson, we identified a **base** and a corresponding **height** in a parallelogram, and then wrote an algebraic expression for finding the area of any parallelogram.

- “How do you decide the base of a parallelogram?” (Any side can be a base. Sometimes one side is preferable over another because its length is known or easy to know.)
- “Once we have chosen a base, how can we identify a height that corresponds to it?” (Identify a perpendicular segment that connects that base and the opposite side; find the length of that segment.)
- “In how many ways can we identify a base and a height for a given parallelogram?” (There are two possible bases. For each base, many possible segments can represent the corresponding height.)
- “What is the relationship between the base and height of a parallelogram and its area?” (The area is the product of base and height.)

5.4 Parallelograms S and T

Cool Down: 5 minutes

Student Task Statement

Parallelograms S and T are each labelled with a base and a corresponding height.

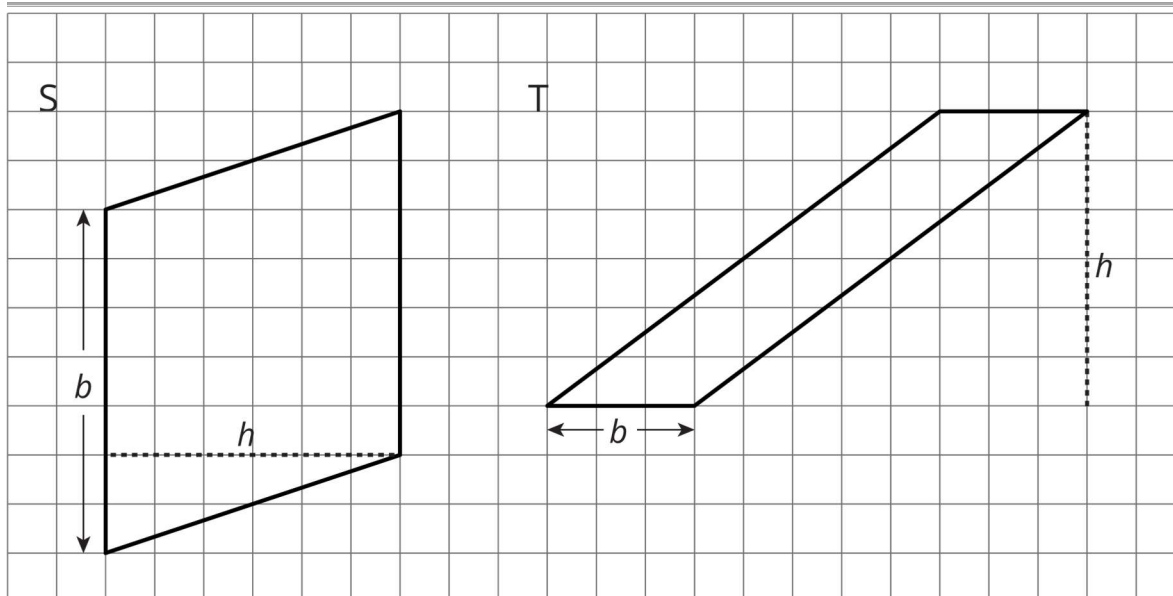

- What are the values of b and h for each parallelogram?
 - Parallelogram S: $b = \underline{\hspace{2cm}}$, $h = \underline{\hspace{2cm}}$
 - Parallelogram T: $b = \underline{\hspace{2cm}}$, $h = \underline{\hspace{2cm}}$
- Use the values of b and h to find the area of each parallelogram.
 - Area of parallelogram S:
 - Area of parallelogram T:

Student Response

- Parallelogram S: $b = 7, h = 6$
- Parallelogram T: $b = 3, h = 6$
- Area of parallelogram S: 42 square units. $7 \times 6 = 42$
- Area of parallelogram T: 18 square units. $3 \times 6 = 18$

Student Lesson Summary

- We can choose any of the four sides of a parallelogram as the **base**. Both the side (the segment) and its length (the measurement) are called the base.
- If we draw any perpendicular segment from a point on the base to the opposite side of the parallelogram, that segment will always have the same length. We call that value the **height**. There are infinitely many segments that can represent the height!

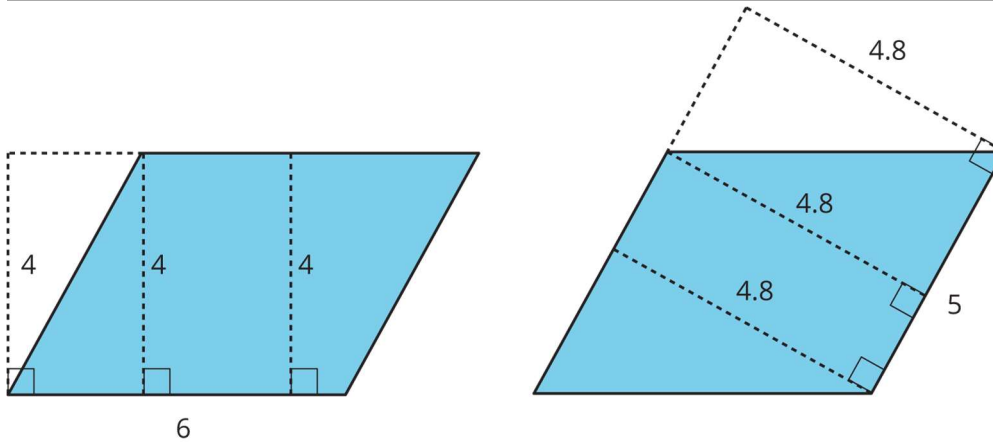

Here are two copies of the same parallelogram. On the left, the side that is the base is 6 units long. Its corresponding height is 4 units. On the right, the side that is the base is 5 units long. Its corresponding height is 4.8 units. For both, three different segments are shown to represent the height. We could draw in many more!

No matter which side is chosen as the base, the area of the parallelogram is the product of that base and its corresponding height. We can check this:

$$4 \times 6 = 24$$

and

$$4.8 \times 5 = 24$$

We can see why this is true by decomposing and rearranging the parallelograms into rectangles.

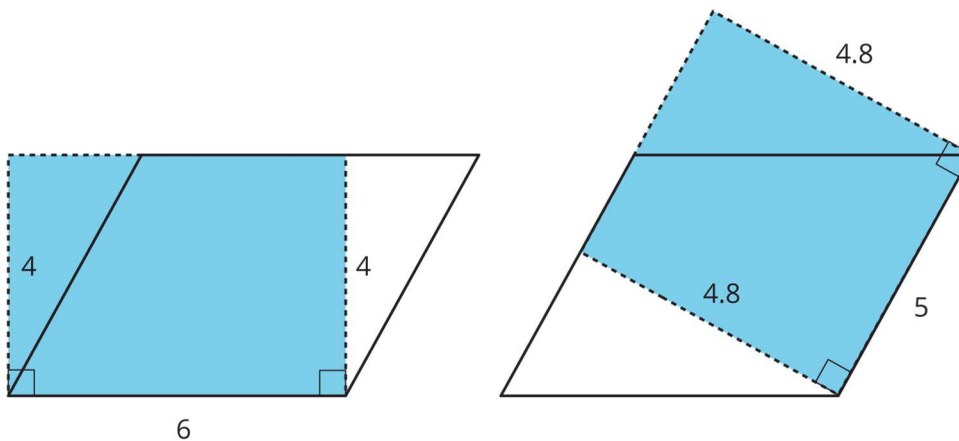

Notice that the side lengths of each rectangle are the base and height of the parallelogram. Even though the two rectangles have different side lengths, the products of the side lengths are equal, so they have the same area! And both rectangles have the same area as the parallelogram.

We often use letters to stand for numbers. If b is base of a parallelogram (in units), and h is the corresponding height (in units), then the area of the parallelogram (in square units) is the product of these two numbers. $b \times h$

In school, you will be able to prove that a perpendicular segment from a point on one side of a parallelogram to the opposite side will always have the same length.

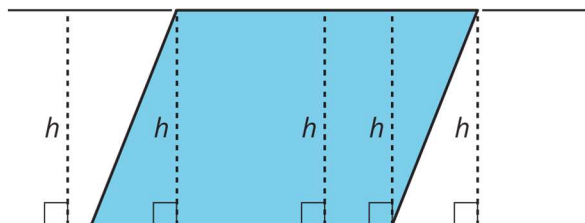

You can see this most easily when you draw a parallelogram on graph paper. For now, we will just use this as a fact.

Glossary

- base (of a parallelogram or triangle)
- height (of a parallelogram or triangle)

Lesson 5 Practice Problems

1. Problem 1 Statement

Select **all** parallelograms that have a correct height labelled for the given base.

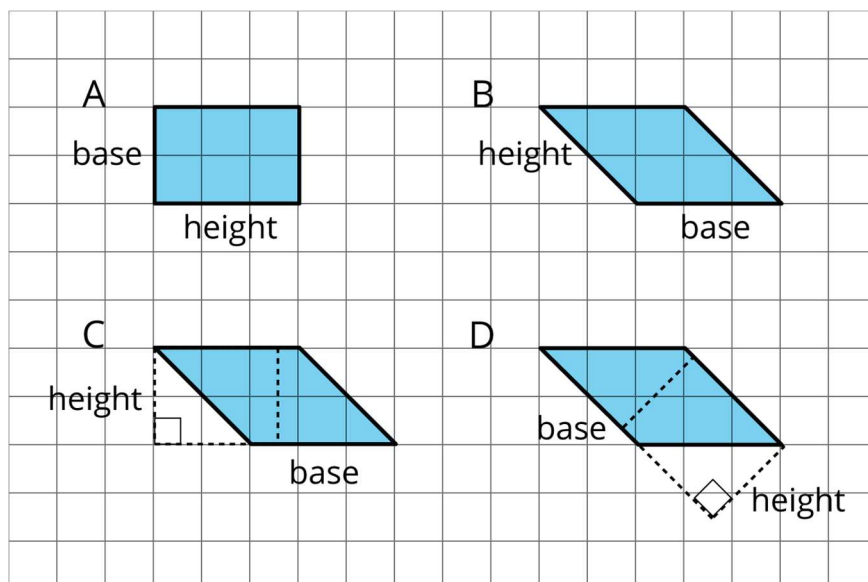

- A
- B
- C

d. D

Solution ["A", "C", "D"]

2. Problem 2 Statement

The side labelled b has been chosen as the base for this parallelogram.

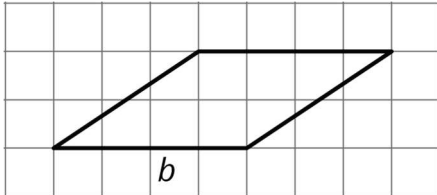

Draw a segment showing the height corresponding to that base.

Solution

Answers vary, (The height can be any segment perpendicular to the base that joins the line containing the base to the line containing the side opposite the base). Sample response:

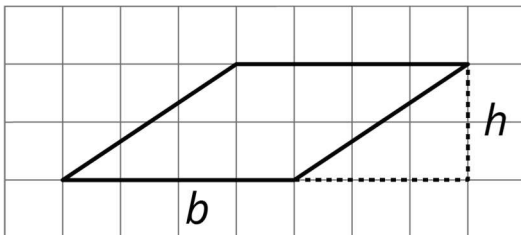

3. Problem 3 Statement

Find the area of each parallelogram.

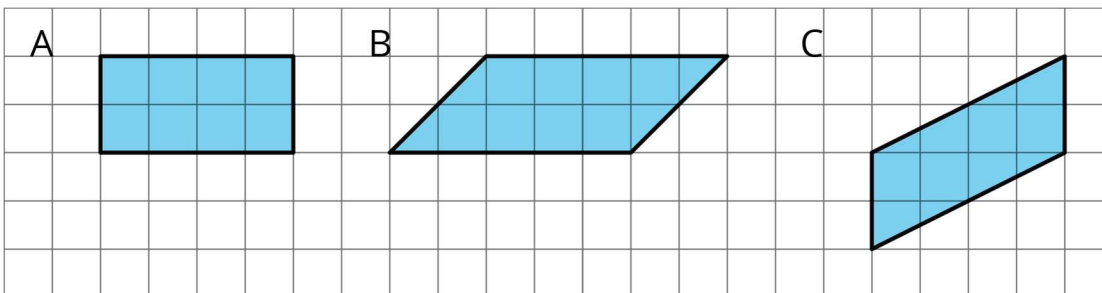

Solution

A: 8 square units. (This is a 2-by-4 rectangle.)

B: 10 square units. (The horizontal side is 5 units long and can be the base. The height for this base is 2 units.)

C: 8 square units. (The vertical side can be used as the base. The base is 2 units, and the height for this base is 4 units.)

4. **Problem 4 Statement**

If the side that is 6 units long is the base of this parallelogram, what is its corresponding height?

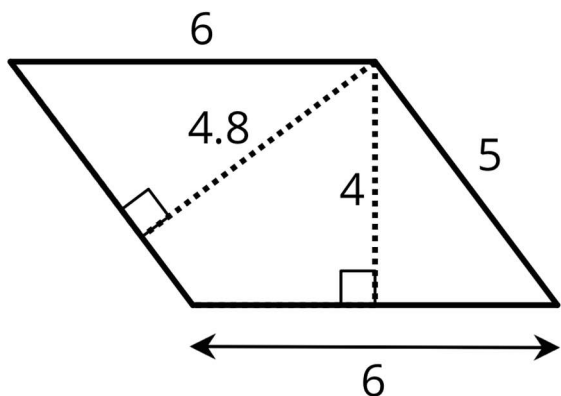

- a. 6 units
- b. 4.8 units
- c. 4 units
- d. 5 units

Solution C

5. **Problem 5 Statement**

Find the area of each parallelogram.

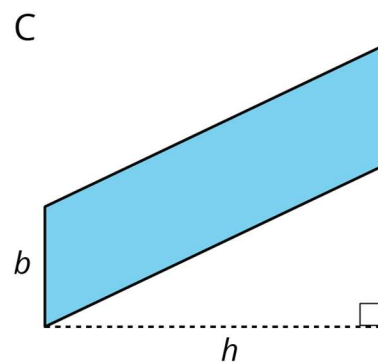
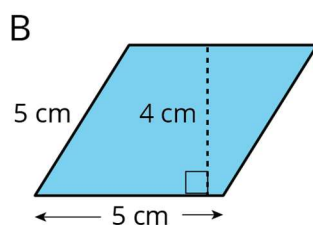
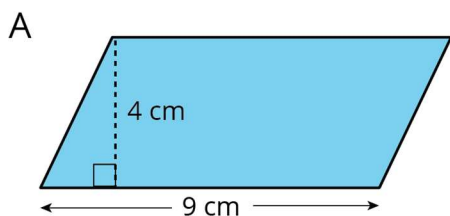

Solution

A: 36 cm^2 . (The base is 9 cm, and the height for that base is 4 cm.)

B: 20 cm^2 . (The base is 5 cm, and the height for this base is 4 cm.)

C: bh . (The base is b , and the corresponding height is h .)

6. Problem 6 Statement

Do you agree with each of these statements? Explain your reasoning.

- A parallelogram has six sides.
- Opposite sides of a parallelogram are parallel.
- A parallelogram can have one pair or two pairs of parallel sides.
- All sides of a parallelogram have the same length.
- All angles of a parallelogram have the same size.

Solution

- Disagree. A parallelogram is a quadrilateral.
- Agree. By definition, opposite sides of a parallelogram are parallel.
- Disagree. By definition, a parallelogram has two pairs of parallel sides.
- Disagree. Sometimes all sides of a parallelogram have the same length, but not always. Opposite sides of a parallelogram always have the same length.
- Disagree. Sometimes all angles of a parallelogram have the same size (when the parallelogram is a rectangle), but not always. Opposite angles of a parallelogram have the same size.

7. Problem 7 Statement

A square with an area of 1 square metre is decomposed into 9 identical small squares. Each small square is decomposed into two identical triangles.

- What is the area, in square metres, of 6 triangles? If you get stuck, consider drawing a diagram.
- How many triangles are needed to compose a region that is $1\frac{1}{2}$ square metres?

Solution

- $\frac{6}{18}$ or $\frac{1}{3}$ square metre.
 - 27 triangles. It takes 18 triangles to make an area of 1 square metre and 9 triangles to make an area of $\frac{1}{2}$ square metre. $18 + 9 = 27$.
-



© These materials were derived and adapted from Illustrative Mathematics's IM 6–8 Math™. IM 6–8 Math was originally developed by Open Up Resources and authored by Illustrative Mathematics®, and is copyright 2017–2019 by Open Up Resources. It is licensed under the Creative Commons Attribution 4.0 International License (CC BY 4.0) <https://creativecommons.org/licenses/by/4.0/>. OUR's 6–8 Math Curriculum is available at <https://openupresources.org/math-curriculum/>. Adaptations and updates to IM 6–8 Math™ are copyright 2019 by Illustrative Mathematics®, and are licensed under the Creative Commons Attribution 4.0 International License (CC BY 4.0). Further adaptations have been made by MEI.