

Lesson 13: Decomposing bases for area

Goals

- Critique (orally) different methods for decomposing and calculating the area of a prism's base.
- Explain (orally and in writing) how to decompose and calculate the area of a prism's base, and then use it to calculate the prism's volume.

Learning Targets

- I can calculate the volume of a prism with a complicated base by decomposing the base into quadrilaterals or triangles.

Lesson Narrative

In this lesson, students continue working with the volume of prisms. They encounter prisms where the base is composed of triangles and rectangles, and decompose the base to calculate the area. They also work with shapes such as heart-shaped boxes or house-shaped shapes where they have to identify the base in order to see the shape as a prism and calculate its volume.

Addressing

- Describe the two-dimensional shapes that result from slicing three-dimensional shapes, as in plane sections of cuboids and rectangular-based pyramids.
- Solve real-world and mathematical problems involving area, volume and surface area of two- and three-dimensional objects composed of triangles, quadrilaterals, polygons, cubes, and prisms.

Instructional Routines

- Co-Craft Questions
- Compare and Connect

Student Learning Goals

Let's look at how some people use volume.

13.1 Are These Prisms?

Warm Up: 10 minutes

The purpose of this warm-up is for students to recognise prisms and their bases. This concept reinforces what was discussed in the previous lesson where students found the volume of different prisms and non-prisms. Students first determine if a given shape is a prism or not and then shade and describe the base of the prism. As students work on the

task, monitor for students who are using precise language to describe the reason a shape is a prism.

Launch

Arrange students in groups of 2. Give students 1 minute of quiet work time followed by time to discuss their answers with a partner. Follow with a whole-class discussion.

Anticipated Misconceptions

If students struggle to see why shape B is a prism, ask them to point out the base of the shape. It might be helpful to remind them that the base of the shape might not always be on the bottom.

Student Task Statement

- Which of these solids are prisms? Explain how you know.

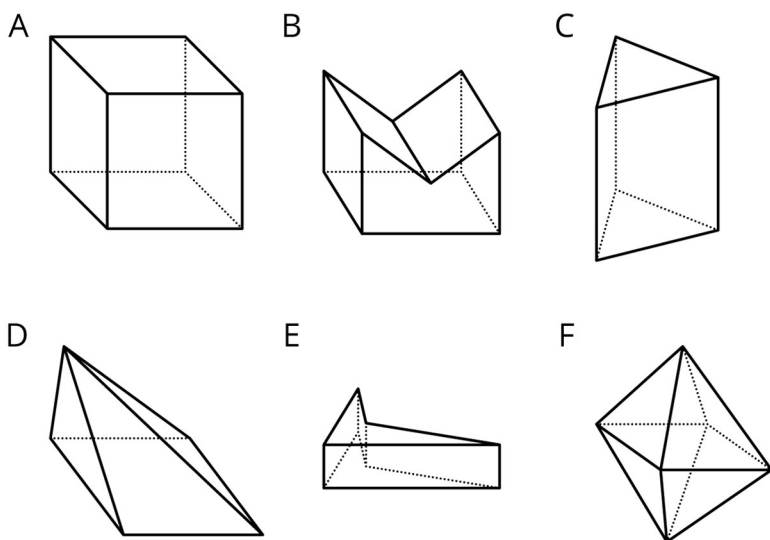

- For each of the prisms, what does the base look like?
 - Shade one base in the picture.
 - Draw a cross section of the prism parallel to the base.

Student Response

- A, B, C, and E are prisms since there is a base shape that is the same on each end with vertices connected by line segments.
- The base for A is a square (any of the faces). The base for B is a pentagon (in the front or back). The base for C is a triangle (on the top or bottom). The base for E is a quadrilateral (on the top or bottom).

Activity Synthesis

Select previously identified students to share their reasoning. Invite students to share the bases they shaded and the drawings of the cross sections. If not mentioned by students, remind them that a shape is considered a prism if the cross section, when cut parallel to the base, has the same shape as the base of the shape.

13.2 A Box of Chocolates

15 minutes

In this activity, students practise mentally dissecting a prism with a non-rectangular base into simpler prisms. The dissection corresponds to a dissection of the base into simpler shapes. This expands on students' ability to calculate the area of a base of a shape that has a rectangular base because here the base is not a rectangle. This prepares students to calculate the volume of this shape and other shapes in future lessons.

As students work in their groups, monitor for the different ways students are decomposing or constructing the base of the shape into more familiar shapes.

Instructional Routines

- Co-Craft Questions

Launch

Arrange students in groups of 3. Display the image for all to see throughout the activity. Tell students this is what the heart-shaped box mentioned in the task statement looks like.

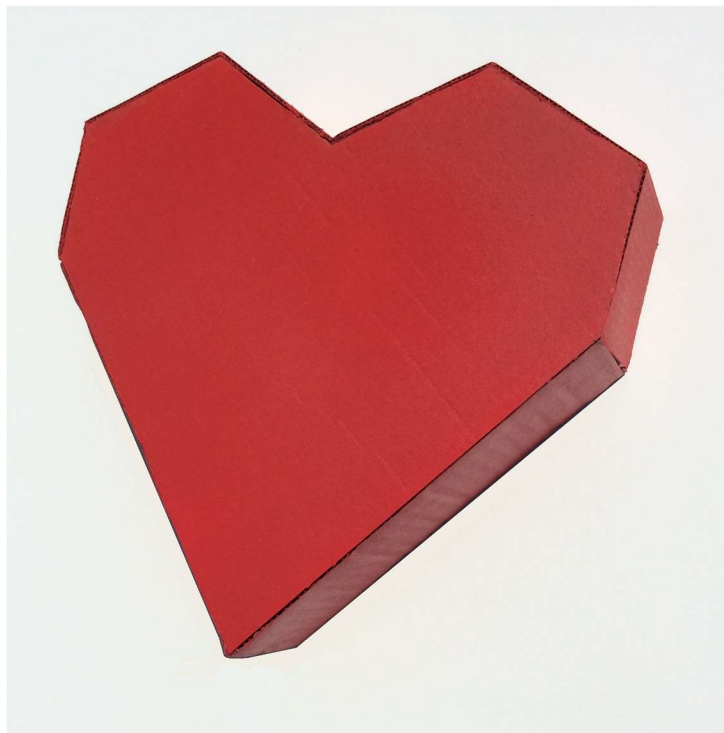

Give students 2–3 minutes of quiet work time followed by a whole-class discussion.

Engagement: Internalise Self Regulation. Check for understanding by inviting students to rephrase directions in their own words. Provide a project checklist that chunks the various steps of the activity into a set of manageable tasks.

Supports accessibility for: Organisation; Attention Conversing: Co-Craft Questions. Display the image of the heart-shaped box and initial task statement without revealing the questions that follow. Ask students to write mathematical questions about the situation. Invite students to share their questions with their group and choose 1 question from their group to share with the class. Listen for questions that connect to finding the area of the base of the heart-shaped prism (e.g., “What’s the most 1 inch by 1 inch by 1 inch chocolates that can fit along the bottom of the box?”). This helps students produce the language of mathematical questions and begin reasoning about different approaches for finding the area of a non-rectangular shape.

Design Principle(s): Cultivate conversation

Student Task Statement

A box of chocolates is a prism with a base in the shape of a heart and a height of 2 inches. Here are the measurements of the base.

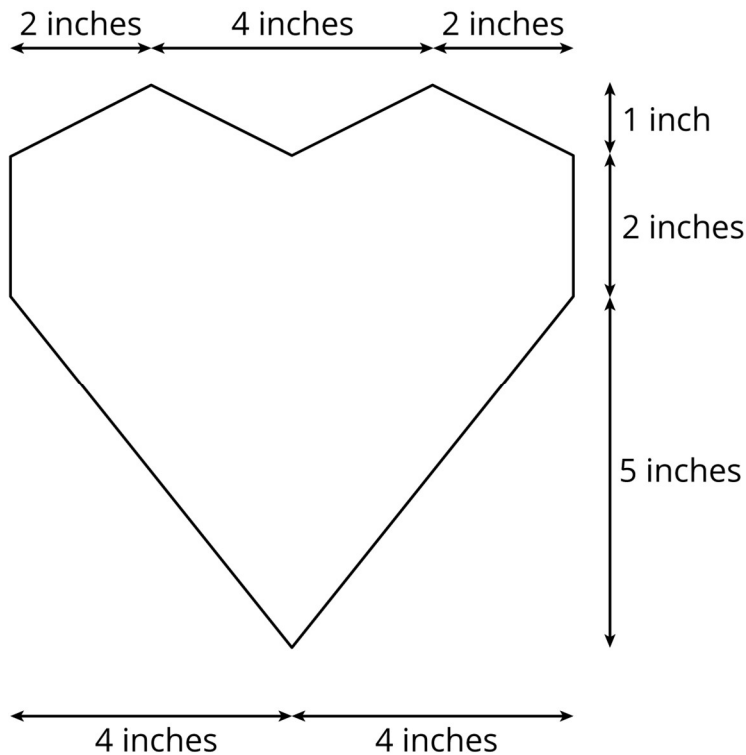

To calculate the volume of the box, three different students have each drawn line segments showing how they plan on finding the area of the heart-shaped base.

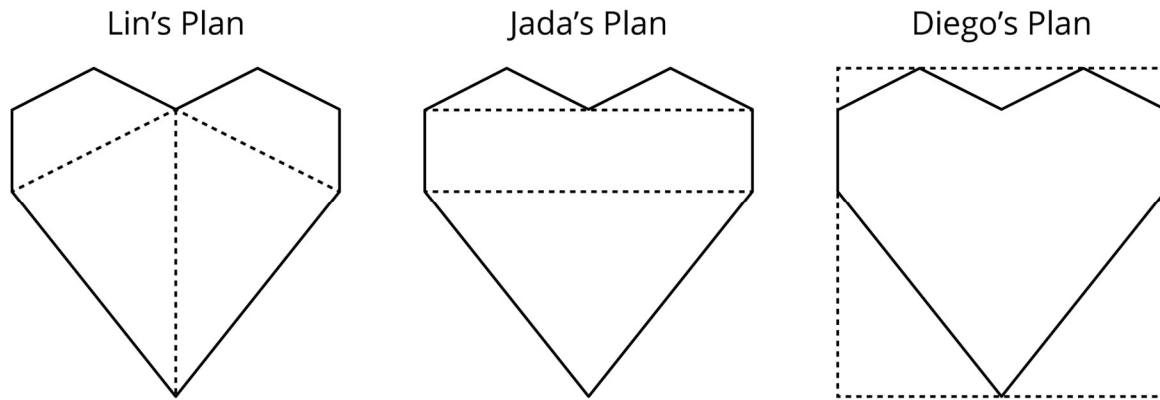

1. For each student's plan, describe the shapes the student must find the area of and the operations they must use to calculate the total area.
2. Although all three methods could work, one of them requires measurements that are not provided. Which one is it?
3. Between you and your partner, decide which of you will use which of the remaining two methods.
4. Using the quadrilaterals and triangles drawn in your selected plan, find the area of the base.
5. Swap with a partner and check each other's work. If you disagree, work to reach an agreement.
6. Return their work. Calculate the volume of the box of chocolates.

Student Response

1. Lin needs to add the areas of the 2 trapeziums and the 2 triangles. Jada needs to add the areas of the 3 triangles and of the rectangle. Diego needs to subtract the areas of the 5 triangles that are not part of the heart design from the area of the square that bounds it.
2. Lin's plan requires measurements that are not given, specifically the bases of each shape and the heights of the trapeziums.
3. Either Jada's plan or Diego's plan.
4. The area of the base is 40 square inches. Using Jada's plan, each of the top triangles has an area of 2 square inches because $\frac{1}{2} \times 1 \times 4 = 2$. The centre rectangle has an area of 16 square inches because $2 \times (4 + 4) = 16$. The lower triangle has an area of 20 square inches, because $\frac{1}{2} \times (4 + 4) \times 5 = 20$. The total area is 40 square inches because $2 + 2 + 16 + 20 = 40$. Using Diego's plan, the bounding square has an area of 64 square inches because $(1 + 2 + 5) \times (4 + 4) = 64$. The top 2 corner triangles each have an area of 1 square inch, because $\frac{1}{2} \times 2 \times 1 = 1$. The top centre triangle has an

area of 2 square inches, because $\frac{1}{2} \times 4 \times 1 = 2$. Each of the 2 lower corner triangles has an area of 10 square inches, because $\frac{1}{2} \times 4 \times 5 = 10$. The total area of all of the triangles is 24 square inches, because $1 + 1 + 2 + 10 + 10 = 24$. The total area of the heart-shaped base 40 square inches, because $64 - 24 = 40$.

5. 40 square inches
6. 80 cubic inches, because $40 \times 2 = 80$.

Are You Ready for More?

The box has 30 pieces of chocolate in it, each with a volume of 1 in^3 . If all the chocolates melt into a solid layer across the bottom of the box, what will be the height of the layer?

Student Response

$$\frac{3}{4} \text{ in}$$

Activity Synthesis

Select students to share whose method they decided to use and why. Ask students:

- “Whose method could not be used? Why not?” (Lin’s, because we don’t know the base and height of the trapeziums.)
- “How did you find the areas of the base?”
- “What was different about the base of this shape in comparison to other bases we have worked with?” (This base needs to be decomposed to calculate its area.)
- “What was the first thing you did to find the volume?” (Use the area of the base and multiply it by the height of the shape.)
- “Why would a chocolatier want to know the volume of a heart shaped box like this?” (He may want to know how many candies can fit inside of a box.)

Explain to students that they might encounter shapes that have non-rectangular bases in future activities or lessons. It will be important for them to think about different strategies to calculate the area of the base.

13.3 Another Prism

10 minutes

In this activity, students practise finding the volume of another prism with a non-rectangular base by applying the formula $\text{Volume} = (\text{Area of the base}) \times (\text{Height of the prism})$.

As students work on the task, monitor for students who decompose or compose the base of the shape into more familiar shapes.

Instructional Routines

- Compare and Connect

Launch

Arrange students in groups of 2. Give students 1–2 minutes of quiet work time followed by time to discuss their work with a partner. Follow with a whole-class discussion.

Representation: Develop Language and Symbols. Display or provide charts with figures and the formula for finding the volume of a prism with a non-rectangular base.

Supports accessibility for: Conceptual processing; Memory

Anticipated Misconceptions

If students mistake the rectangle for the base of the shape, ask students how we know that this shape is a prism and what the base of this shape needs to be in order to consider it a prism.

Student Task Statement

A house-shaped prism is created by attaching a triangular prism on top of a cuboid.

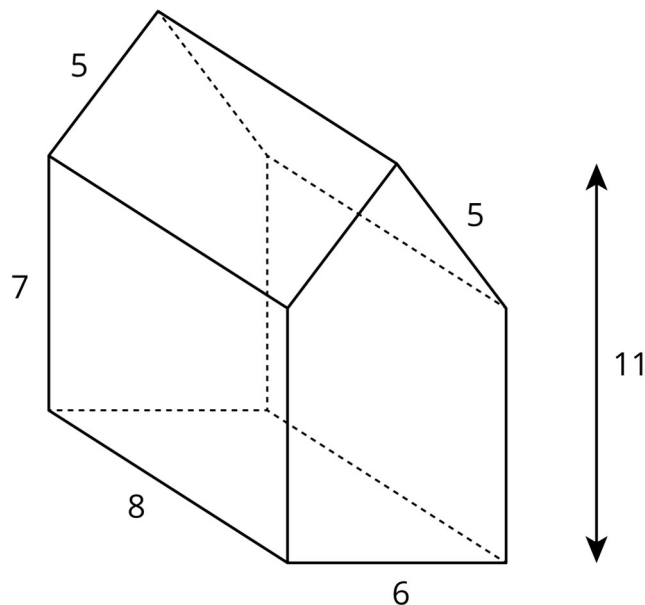

1. Draw the base of this prism and label its dimensions.
2. What is the area of the base? Explain or show your reasoning.
3. What is the volume of the prism?

Student Response

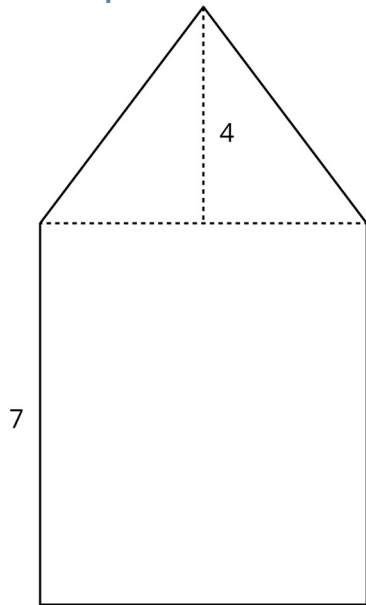

1. 6
2. 54 square units. This shape can be divided into a rectangle and triangle. The area of the rectangle is $6 \times 7 = 42$. The area of the triangle is $\frac{1}{2} \times 4 \times 6 = 12$. So, the area of the base is $42 + 12 = 54$.
3. 432 cubic units. Since the volume of a prism is the area of the base times the height of the prism, the volume is $8 \times 54 = 432$.

Activity Synthesis

Select previously identified students to share the different methods for calculating the area of the base. If not brought up by students, explain to students that the base of this shape can be either decomposed into rectangles and triangles or composed into a larger rectangle by adding two additional triangles. Ask students how they used the area of the base to calculate the volume of the shape (area of the base multiplied by the height).

Speaking, Listening: Compare and Connect. Use this routine as students explain their strategy for calculating the volume of the prism. Ask students to consider what is the same and what is different about each approach. Draw students' attention to the different ways the shape was decomposed and highlight any use of mathematical language (e.g., decompose, rectangle, triangle, trapezium). These exchanges can strengthen students' mathematical language use and reasoning of prisms.

Design Principle(s): Optimise meta-awareness; Support sense-making

Lesson Synthesis

- "When the base is not a rectangle or triangle, what are some methods for finding the area?" (We can cut the base apart into rectangles and triangles or imagine a larger shape that has been cut into the base.)

Here, we mostly imagined cutting the base apart to find its area, but we could have imagined cutting the original object into smaller objects, then finding the volume of each piece and adding them together.

13.4 Volume of a Pentagonal Prism

Cool Down: 5 minutes

Launch

If desired, provide copies of the two-dimensional view of just the base of the prism.

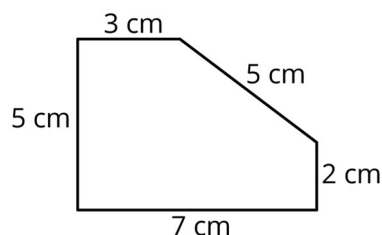

Student Task Statement

Here is a prism with a pentagonal base. The height is 8 cm.

What is the volume of the prism? Show your thinking. Organise it so it can be followed by others.

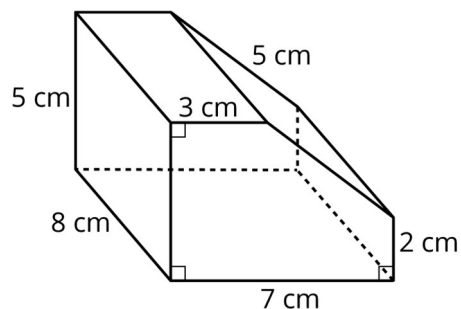

Student Response

The volume is 232 cm^3 . The area of the base is 29 cm^2 and can be found in multiple ways, but one way is to consider a 5 by 7 rectangle with a right-angled triangle cut off, then $5 \times 7 - \frac{1}{2} \times 4 \times 3 = 29$. Since the height is 8 cm, the volume is calculated by $29 \times 8 = 232$.

Student Lesson Summary

To find the area of any polygon, you can decompose it into rectangles and triangles. There are always many ways to decompose a polygon.

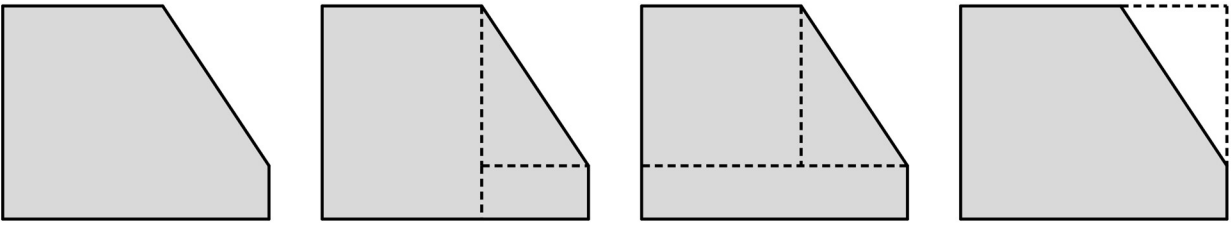

Sometimes it is easier to enclose a polygon in a rectangle and subtract the area of the extra pieces.

To find the volume of a prism with a polygon for a base, you find the area of the base, B , and multiply by the height, h .

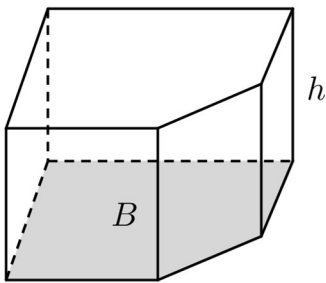

$$V = Bh$$

Lesson 13 Practice Problems

1. Problem 1 Statement

You find a crystal in the shape of a prism. Find the volume of the crystal.

The point B is directly underneath point E , and the following lengths are known:

- From A to B : 2 mm
- From B to C : 3 mm
- From A to F : 6 mm
- From B to E : 10 mm
- From C to D : 7 mm
- From A to G : 4 mm

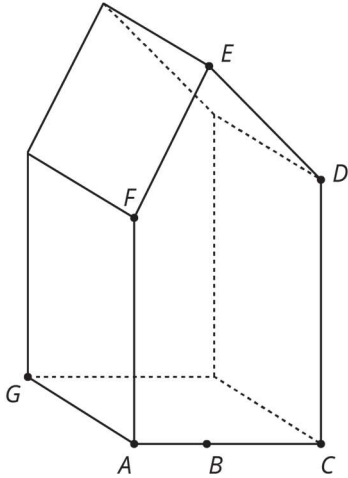

Solution

166 cubic millimetres

2. Problem 2 Statement

A cuboid with dimensions 5 inches by 13 inches by 10 inches was cut to leave a piece as shown in the image. What is the volume of this piece? What is the volume of the other piece not pictured?

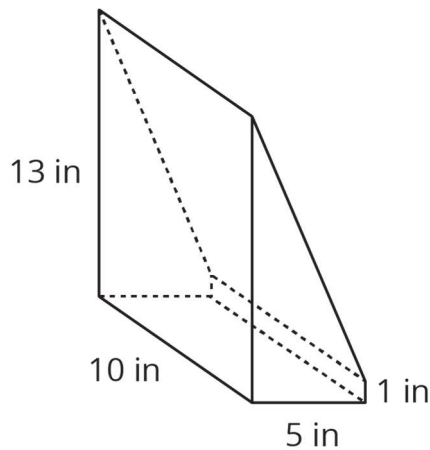

Solution

350 cubic inches, 300 cubic inches

3. Problem 3 Statement

A triangle has one side that is 7 cm long and another side that is 3 cm long.

- a. Sketch this triangle and label your sketch with the given measurements. (If you are stuck, try using a compass or cutting some straws to these two lengths.)

- b. Draw one more triangle with these measurements that is not identical to your first triangle.
- c. Explain how you can tell they are not identical.

Solution

- a. Answers vary.
- b. Answers vary.
- c. Responses vary. Sample response: If I cut one of the triangles out and place it on top of the other triangles, the triangles do not match up.

4. Problem 4 Statement

Select **all** equations that represent a relationship between angles in the diagram.

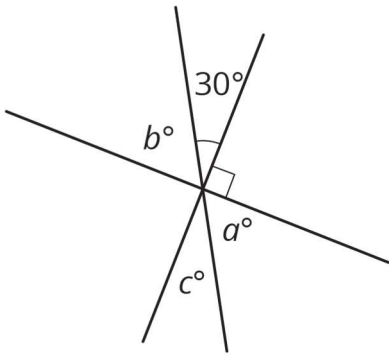

- a. $90 - 30 = b$
- b. $30 + b = a + c$
- c. $a + c + 30 + b = 180$
- d. $a = 30$
- e. $a = c = 30$
- f. $90 + a + c = 180$

Solution ["A", "B", "C", "F"]

5. Problem 5 Statement

A mixture of punch contains 1 quart of lemonade, 2 cups of grape juice, 4 tablespoons of honey, and $\frac{1}{2}$ gallon of sparkling water. Find the percentage of the punch mixture that comes from each ingredient. Round your answers to the nearest tenth of a percent. (Hint: 1 cup = 16 tablespoons, 1 quart = 4 cups, 1 gallon = 16 cups)

Solution

Lemonade: 28.1%, Grape Juice: 14.0%, Honey: 1.8%, Sparkling Water: 56.1%



© These materials were derived and adapted from Illustrative Mathematics's IM 6–8 Math™. IM 6–8 Math was originally developed by Open Up Resources and authored by Illustrative Mathematics®, and is copyright 2017–2019 by Open Up Resources. It is licensed under the Creative Commons Attribution 4.0 International License (CC BY 4.0) <https://creativecommons.org/licenses/by/4.0/>. OUR's 6–8 Math Curriculum is available at <https://openupresources.org/math-curriculum/>. Adaptations and updates to IM 6–8 Math™ are copyright 2019 by Illustrative Mathematics®, and are licensed under the Creative Commons Attribution 4.0 International License (CC BY 4.0). Further adaptations have been made by MEI.