

Lesson 11: Polygons

Goals

- Compare and contrast (orally) different strategies for finding the area of a polygon.
- Describe (orally and in writing) the defining characteristics of polygons.
- Find the area of a polygon, by decomposing it into rectangles and triangles, and present the solution method (using words and other representations).

Learning Targets

- I can describe the characteristics of a polygon using mathematical vocabulary.
- I can reason about the area of any polygon by decomposing and rearranging it, and by using what I know about rectangles and triangles.

Lesson Narrative

Students have worked with polygons in earlier years and throughout this unit. In this lesson, students write a definition that characterises polygons. There are many different accurate definitions for a **polygon**. The goal of this lesson is not to find the most succinct definition possible, but to articulate the defining characteristics of a polygon that make sense to students.

Another key takeaway for this lesson is that the area of any polygon can be found by decomposing it into triangles. The proof that all polygons are *triangulable* (not a word students need to know) is fairly sophisticated, but students can just take it as a fact for now. In observing and using this fact students look for and make use of structure.

Building On

- Classify two-dimensional shapes based on the presence or absence of parallel or perpendicular lines, or the presence or absence of angles of a specified size. Recognise right-angled triangles as a category, and identify right-angled triangles.
- Classify two-dimensional shapes into categories based on their properties.

Addressing

- Find the area of right-angled triangles, other triangles, special quadrilaterals, and polygons by composing into rectangles or decomposing into triangles and other shapes; apply these techniques in the context of solving real-world and mathematical problems.

Building Towards

- Find the area of right-angled triangles, other triangles, special quadrilaterals, and polygons by composing into rectangles or decomposing into triangles and other shapes; apply these techniques in the context of solving real-world and mathematical problems.

Instructional Routines

- Group Presentations
- Collect and Display
- Discussion Supports
- Think Pair Share
- Which One Doesn't Belong?

Required Materials

Geometry toolkits

tracing paper, graph paper, coloured pencils, scissors, and an index card to use as a straightedge or to mark right angles.

Required Preparation

If doing the optional Pinwheel activity, prepare one copy of the blackline master for every group of 4 students. If larger paper (and a photocopier that can accommodate it) is available, it would be helpful to have larger-format copies of this.

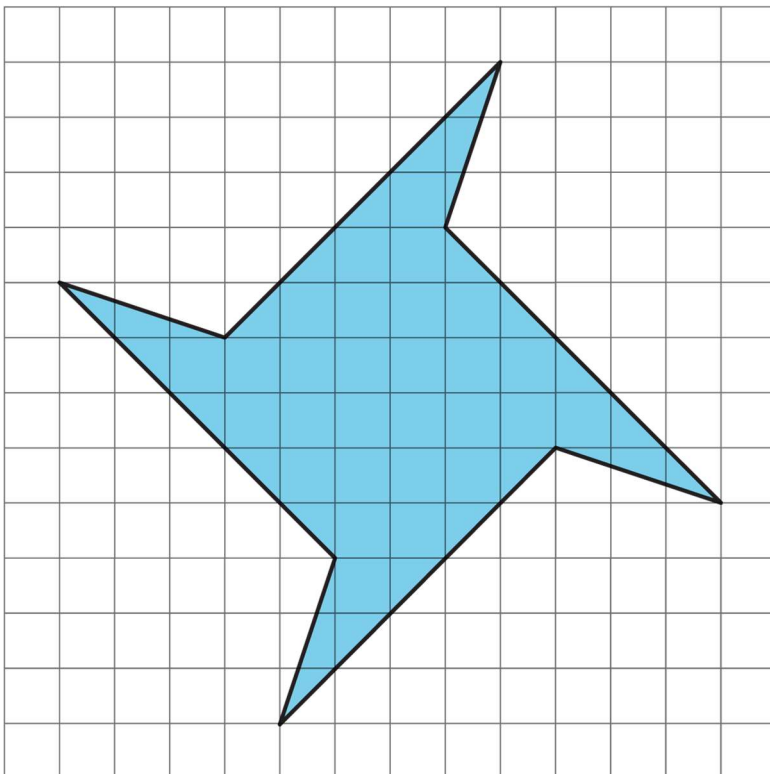

Student Learning Goals

Let's investigate polygons and their areas.

11.1 Which One Doesn't Belong: Bases and Heights

Warm Up: 5 minutes

This warm-up prompts students to consolidate what they learned in the past few lessons and make careful observations about triangles.

Expect students to describe the differences in the triangles in terms of:

- angles (acute, right, or obtuse)
- orientation of sides (vertical, horizontal)
- the side likely to be chosen as a base
- length of base or height

Instructional Routines

- Which One Doesn't Belong?

Launch

Arrange students in groups of 2–4. Display the image of triangles for all to see. Give students 1 minute of quiet think time and ask them to indicate when they have noticed one triangle that does not belong and can explain why. Encourage them to think of more than one possibility.

When the minute is up, give students 2 minutes to share their response with their group, and then together find at least one reason, if possible, that each triangle doesn't belong.

Student Task Statement

Which one doesn't belong?

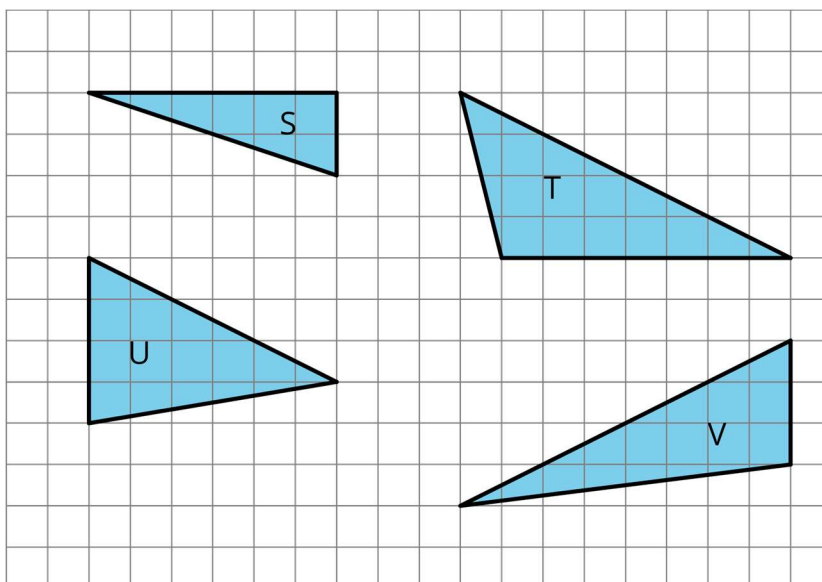

Student Response

Answers vary. Sample responses:

- S: It is the only right-angled triangle. It is the only one where two sides can be easily chosen as a base and used to find the area. It is the only one where the base and height are both sides of the triangle.
- T: It is the only triangle with no vertical side. It is the only triangle where the side most likely to be chosen as a base is horizontal.
- U: It is the only acute triangle. It is the only triangle that is most likely to have its height drawn inside the triangle.
- V: It is the only one with a height greater than 7 units.

Activity Synthesis

After students shared their observations in groups, invite each group to share one reason why a particular triangle might not belong. Record and display the responses for all to see. After each response, poll the rest of the class to see if others made the same observation.

Since there is no single correct answer to the question of which pattern does not belong, attend to students' explanations and ensure the reasons given are correct. Prompt students to explain the meaning of any terminology they use (parts of triangles, types of angles, etc.) and to substantiate their claims.

11.2 What Are Polygons?

20 minutes

Developing a useful and complete definition of a polygon is harder than it seems. A formal definition is often very wordy or hard to parse. Polygons are often referred to as “closed” shapes, but if used, this term needs to be defined, as the everyday meaning of “closed” is different than its meaning in a geometric context.

This activity prompts students to develop a working definition of polygon that makes sense to them, but that also captures all of the necessary aspects that makes a shape a polygon. Here are some important characteristics of a polygon.

- It is composed of line segments. Line segments are always straight.
 - Each line segment meets one and only one other line segment at each end.
 - The line segments never cross each other except at the end points.
 - It is two-dimensional.
-

One consequence of the definition of a polygon is that there are always as many vertices as edges. Students may observe this and want to include it in their definition, although technically it is a result of the definition rather than a defining feature.

As students work, monitor for both correct and incorrect definitions of a polygon. Listen for clear and correct descriptions as well as common but inaccurate descriptions (so they can be discussed and refined later). Notice students with accurate explanations so they could share later.

Instructional Routines

- Collect and Display

Launch

Arrange students in groups of 2–4. Give students 3–4 minutes of quiet think time. Afterwards, ask them to share their responses with their group and complete the second question together. If there is a disagreement about whether a shape is a polygon, ask them to discuss each point of view and try to come to an agreement. Follow with a whole-class discussion.

Conversing, Representing, Writing: Collect and Display. As students work, listen for, collect, and display terms and phrases students use to describe key characteristics of polygons (e.g., polygon, edge, vertices). Remind students to borrow language from the display as needed. This will help students use mathematical language when describing polygons.

Design Principle(s): Support sense-making; Maximise meta-awareness

Anticipated Misconceptions

Students may think that shapes C and I are polygons because they can see several triangles or quadrilaterals in each shape. Ask students to look closely at the examples and non-examples and see there is a shape composed of multiple triangles or quadrilaterals, and if so, to see in which group it belongs.

Student Task Statement

Here are five **polygons**:

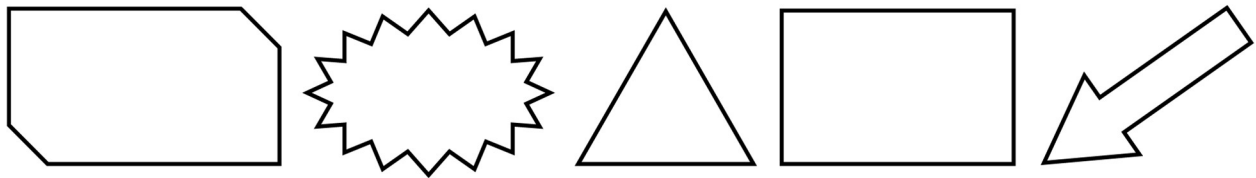

Here are six shapes that are *not* polygons:

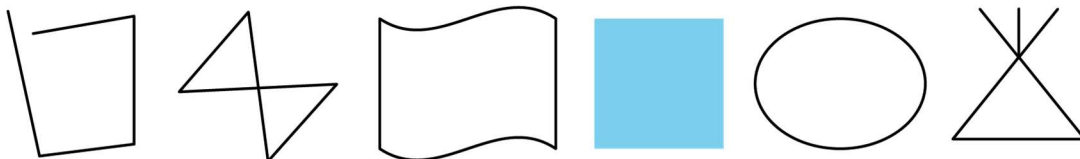

1. Circle the shapes that are polygons.

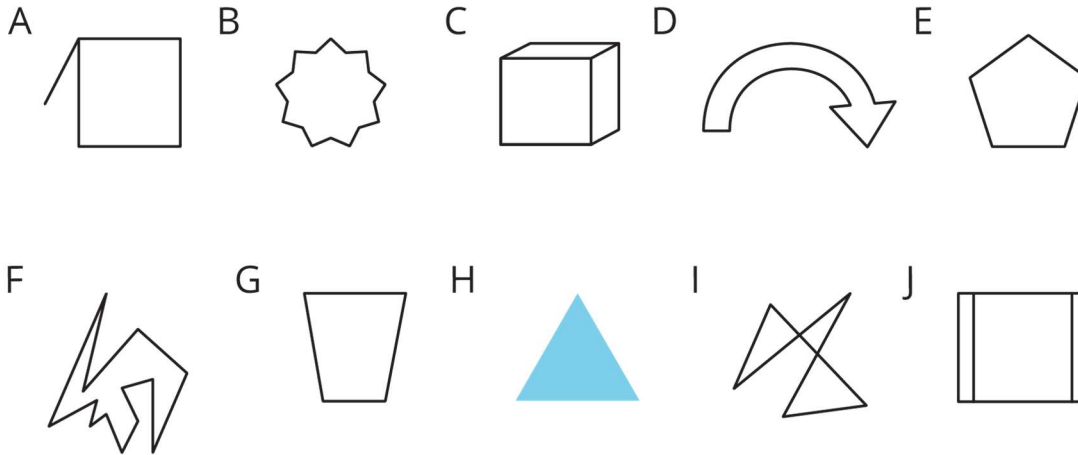

2. What do the shapes you circled have in common? What characteristics helped you decide whether a shape was a polygon?

Student Response

1. B, E, F, and G are polygons.
2. Answers vary. Characteristics that the polygons have in common: They are two-dimensional, composed of line segments that never cross each other, and each line segment meets one and only one other line segment at each end.

Activity Synthesis

Display the shapes in the first question for all to see. For each shape, ask at least one student to explain why they think it is or is not a polygon. (It is fine if students' explanations are not precise at this point.) Then, circle the shapes that are polygons on the visual display.

Next, ask students to share their ideas about the characteristics of polygons. Record them for all to see. For each one, ask the class if they agree or disagree. If they generally agree, ask if there is anything they would add or elaborate on to make the description clearer or more precise. If they disagree, ask for an explanation.

If a key characteristic listed in the Activity Narrative is not mentioned by students, bring it up and revisit it at the end of the lesson.

Tell students we call the line segments in a polygon the **edges** or **sides**, and we call the points where the edges meet the **vertices**. Point to the sides and vertices in a few of the identified polygons.

Point out that polygons always enclose a region, but the region is not technically part of the polygon. When we talk about finding the area of a polygon, we are in fact finding the area of

the region it encloses. So “the area of a triangle,” for example, is really shorthand for “area of the region enclosed by the triangle.”

Representation: Develop Language and Symbols. Create a display of important terms and vocabulary. Invite students to suggest language or diagrams to include that will support their understanding. Include the following terms and maintain the display for reference throughout the unit: vertex, vertices, edge, polygon.

Supports accessibility for: Language; Conceptual processing

11.3 Quadrilateral Strategies

15 minutes

This activity has several aims. It prompts students to apply what they learned to find the area of quadrilaterals that are not parallelograms, encourages them to plan before jumping into a problem, and urges them to reflect on the merits of different methods.

Students begin by thinking about the moves they would make to find the area of a quadrilateral and explaining their preference to their partners. They then consider and discuss the different strategies taken by other students. Along the way, they may notice that some strategies are more direct or efficient than others. Students reflect on these strategies and use their insights to plan the work of finding the area of polygons in this activity and beyond.

Note that it is unnecessary for students to take the most efficient path. It is more important that they choose an approach that makes sense to them but have the chance to see the pros and cons of various paths.

Instructional Routines

- Discussion Supports
- Think Pair Share

Launch

Ask students to recall the definition of **quadrilateral** from KS2, or tell students that a quadrilateral is a polygon with 4 sides. Tell students that we will now think about how to find the area of quadrilaterals.

Arrange students in groups of 4. Display the image of quadrilaterals A–F for all to see. Direct their attention to quadrilateral D.

Give students a minute of quiet time to think about the first 2–3 moves they would make to find the area of D. Offer some sentence starters: “First, I would . . . Next I would . . . , and then I would . . .” Encourage them to show their moves on the diagram in their material.

Emphasise that we are interested only in the plan for finding area and not in the area itself, so no calculation is expected. Then, give them 1–2 minutes to share their moves with their group.

Ask students to indicate what their first move was. Did their very first involve:

- decomposing the quadrilateral?
- enclosing the quadrilateral?
- another move?

Ask the students whose first move is to decompose the shape:

- “How many pieces resulted from the decomposition? 2 pieces? 3 pieces? 4 pieces? More?”
- “What is the next move? Rearrange? Duplicate a piece? Calculate the area of a piece? Something else?”

Ask the students whose first move is to enclose the shape:

- “How many rectangles did you create? 1 rectangle? 2 rectangle? More?”
- “What is the next move? Rearrange the extra pieces? Calculate the area of an extra piece? Something else?”

For each sequence that students mentioned, draw a quick diagram to illustrate it for all to see.

Once students have a chance to see a variety of approaches, ask students to revisit their sequence of moves. Give students 1–2 minutes to think about the pros and cons of their original plan, and if there was another strategy that they found productive. Invite a few students to share their reflections.

Then, give students quiet time to complete the activity and access to their geometry toolkits. Ask students to keep in mind the merits of the different strategies they have seen as they plan their work.

Student Task Statement

Find the area of *two quadrilaterals* of your choice. Show your reasoning.

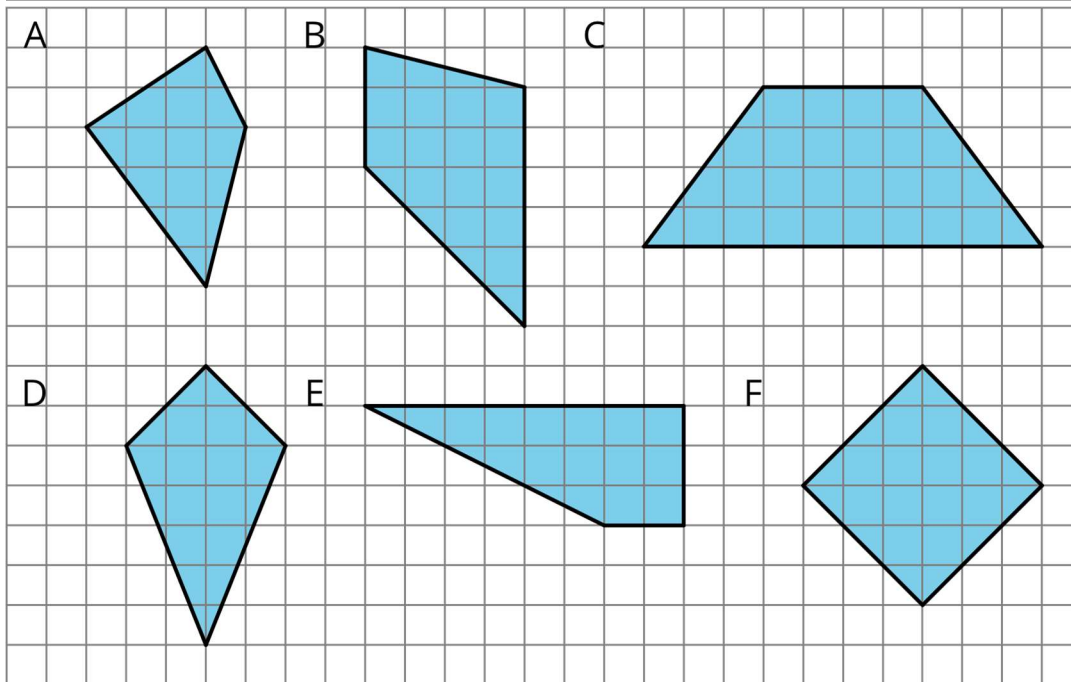

Student Response

Reasoning varies. Students could decompose the quadrilateral into parallelograms and triangles to find the area, decompose and rearrange the pieces into a shape of which they can easily find the area, or enclose the shape in a rectangle and subtract the area of the extra pieces.

Shape A: 12 square units

Shape B: 18 square units

Shape C: 28 square units

Shape D: 14 square units

Shape E: 15 square units

Shape F: 18 square units

Are You Ready for More?

Here is a trapezium. a and b represent the lengths of its bottom and top sides. The segment labelled h represents its height; it is perpendicular to both the top and bottom sides.

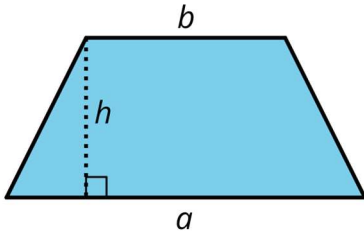

Apply area-reasoning strategies—decomposing, rearranging, duplicating, etc.—on the trapezium so that you have one or more shapes with areas that you already know how to find. Use the shapes to help you write a formula for the area of a trapezium. Show your reasoning.

Student Response

Students may cut the trapezium in half horizontally, rotate the top piece and attach it to the bottom piece. They see that they can add the top and bottom side lengths and multiply that by half of the original height. This is built on prior understanding of finding the area of a parallelogram. $\frac{1}{2} \times h \times (a + b)$

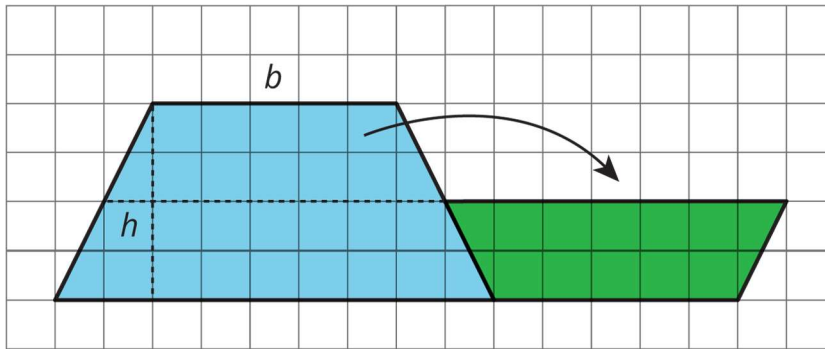

Students may also put an identical copy of the same trapezium next to the original to make a parallelogram. Then, find the area of the parallelogram and divide that by 2. $(a + b) \times h \div 2$

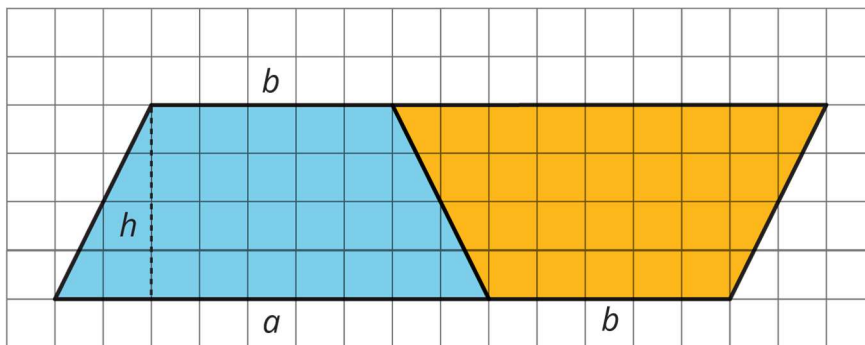

Another way to approach this is to draw a diagonal and add the areas of the two resulting triangles. $a \times h \div 2 + b \times h \div 2$

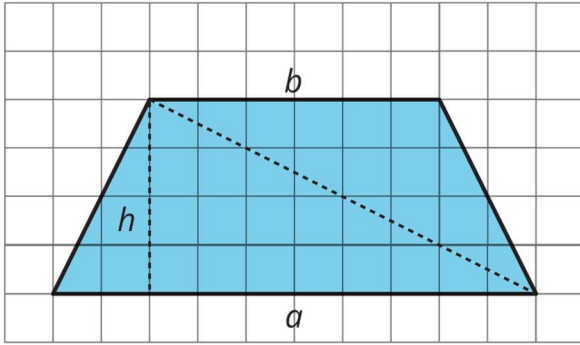

Activity Synthesis

To conclude the activity, ask students to choose one quadrilateral they worked on (other than D) and tell their group the first couple of moves they made for finding its area and why. Encourage other group members to listen carefully, check that the reasoning is valid, and offer feedback.

Students may have noticed that all the approaches involved decomposing one or more regions into triangles, rectangles, or both. If not mentioned by students, point this out. Emphasise that we can decompose any polygon into triangles and rectangles to find its area.

Speaking: Discussion Supports. Use this routine before groups share the first couple of moves they made to find the area of one of the quadrilaterals. Ask the class, “What are some important words or phrases you can use when you describe the moves you made?” Record and display student responses. In addition to the relevant mathematical terms, call students' attention to the language that helps to communicate order within the approaches. Remind students to use the display as a resource during their group discussions.

Design Principle(s): Optimise output (for explanation); Maximise meta-awareness

11.4 Pinwheel

Optional: 30 minutes

In this activity, students determine the area of an unfamiliar polygon and think about various ways for doing so. The task prepares students to find the areas of other unfamiliar shapes in real-world contexts. It also reinforces the practice of sense-making, planning, and persevering when solving a problem. Students reason independently before discussing and recording their strategies in groups.

Because the shape of the polygon is more complex than what students may have seen so far, expect students to experiment with one or more strategies. Consider preparing extra copies of the diagram for students to use, if needed.

As students work, monitor the paths taken by different groups and make note of the variations and complexities. If there is limited variation in strategies, look for groups who recorded the same strategy in different ways. Also check whether students make use of the structure of the pinwheel in their reasoning. Do they notice it could be decomposed into

four identical pieces (or sets of pieces)? Or, if enclosing the pinwheel with a square, do they make use the fact that the extra regions are identical?

Instructional Routines

- Group Presentations
- Collect and Display

Launch

Arrange students in groups of 4. Give students access to their geometry toolkits and 5 minutes of quiet time to plan an approach for finding the area of the pinwheel. Then, ask them to share their plan with their group.

The group then decides on one or more strategies to pursue, works together to find the area, and creates a visual display of the strategy (or strategies) used. Give each group one or more copies of the blackline master for the visual display.

Engagement: Develop Effort and Persistence. Connect a new concept to one with which students have experienced success. Remind students that triangles can be decomposed, rearranged, enclosed, or duplicated to determine area.

Supports accessibility for: Social-emotional skills; Conceptual processing

Anticipated Misconceptions

Students who overlay a rotated square over the shape such that the four pins are shown as four right-angled triangles may use incorrect side lengths for the triangles (e.g. assuming that one of the side lengths are 2 units instead of $2\sqrt{2}$ units) or the square. Help them see that the diagonals of the unit squares are longer than the side length by measuring them.

If students struggle, suggest they use one or more of the tools in their toolkits to assist with solving the problem.

Student Task Statement

Find the area of the shaded region in square units. Show your reasoning.

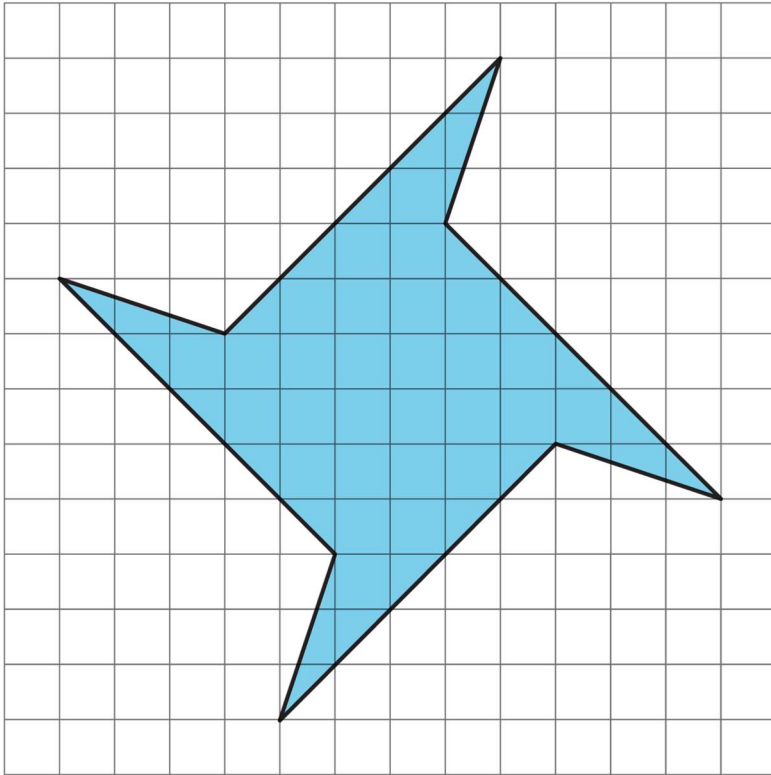

Student Response

The area is 40 square units.

There are many ways to decompose this shape. Sample responses:

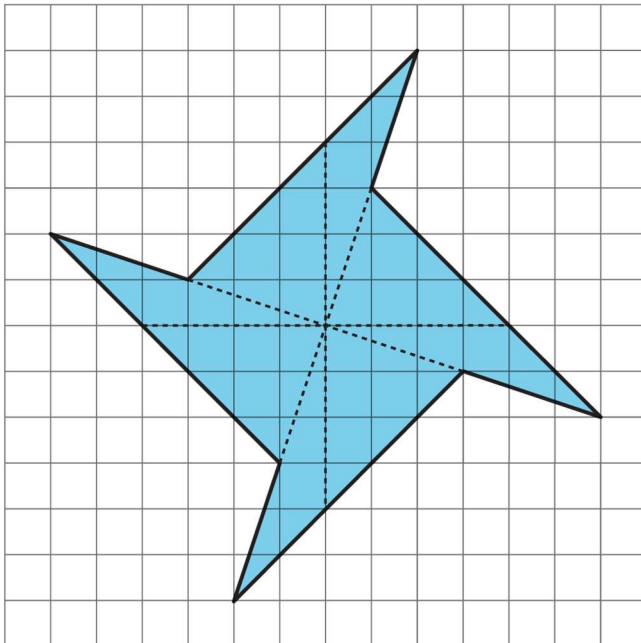

There are two different triangles duplicated 4 times. Both can be found by enclosing in rectangles and subtracting the areas of right-angled triangles, or by using the formula for the area of a triangle. $4 \times \frac{1}{2}(3 \times 4 + 2 \times 4) = 40$

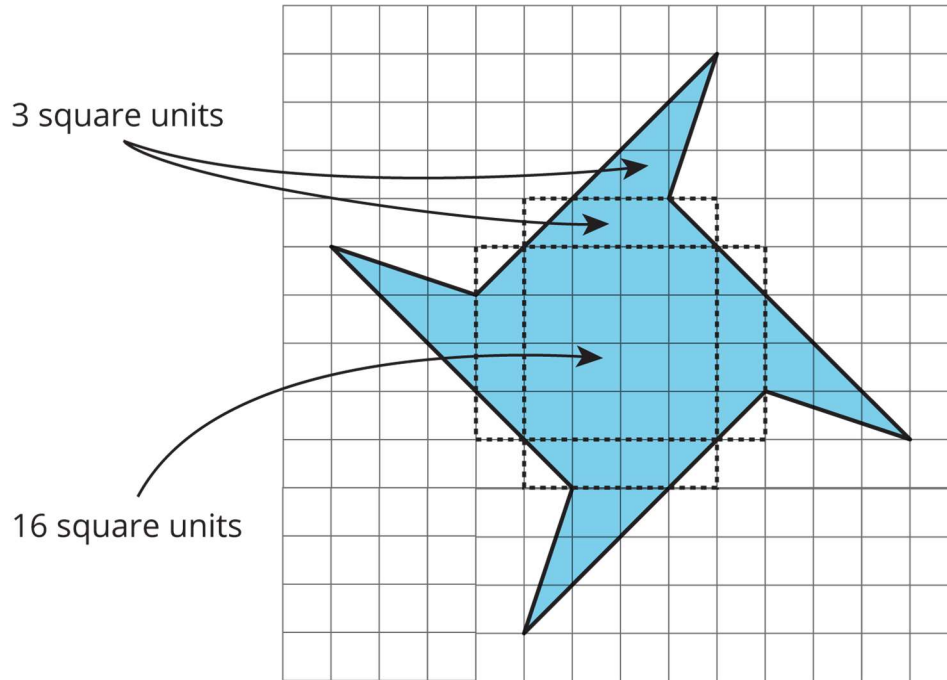

The middle of the pinwheel is a square with the area of 16 square units. Around the square are 4 trapeziums that students can find the area of by enclosing and subtracting the area of the extra pieces or decomposing and rearranging to a rectangle with an area of 3 square units. Around each trapezium is a triangle that students can find the area of using the formula for the area of a triangle to find each one is 3 square units.

Activity Synthesis

Ask the groups to visit one another's visual display and discuss the following questions as they observe others' work:

- Did this group arrive at the same area as our group? If not, why?
- How is their strategy like our strategy?
- How is their strategy different than ours?

After the gallery walk, ask a few students to comment on how their group's strategy compares to that of another group. Highlight similarities in students' work in broader terms. For example, all groups have likely used one of the following approaches:

- decomposed the pinwheel into triangles and used the formula to find the area of the triangles

- decomposed the pinwheel into triangles and rectangles, rearranged the pieces into rectangles or parallelograms, and found the areas of those regions
- enclosed the pinwheel with a square, decomposed the extra regions into triangles and rectangles, found their area of the extra regions, and subtracted them from that of the square

Reinforce that all approaches involve decomposing a polygon into triangles and rectangles to find area.

Conversing, Representing: Collect and Display. During the gallery walk, circulate and listen to students talk about the similarities and differences between the different strategies. Listen for common phrases you hear students say about each strategy, and record students' words onto a visual display of the pinwheel. This will help students make connections between the strategies, and also provide them with mathematical language to use during the whole-class discussion.

Design Principle(s): Support sense-making

Lesson Synthesis

To review the defining characteristics of a **polygon**, return to the image in the first activity (What are Polygons?) and display the list of defining features students generated in that activity.

Revisit each shape that is *not* a polygon and ask students to explain why it is not a polygon. Encourage students to use their list to support their explanations, as well as to suggest revisions to their working definition.

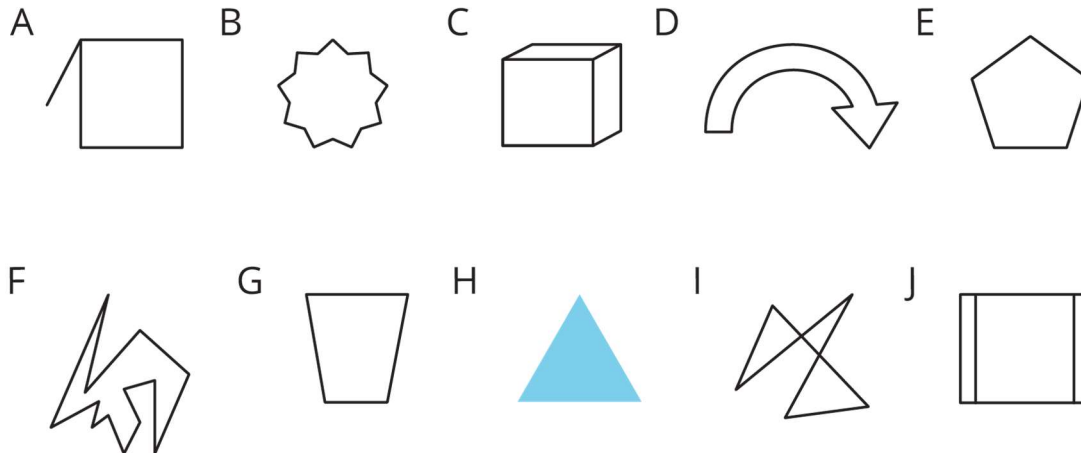

Here is a polygon with 5 sides.

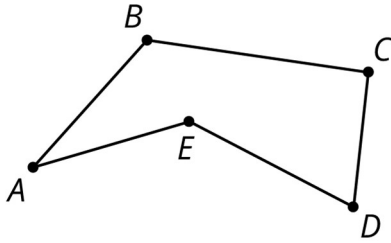

Ask students:

- “How do we know this shape is a polygon?” (It is composed of line segments. Each segment meets only one other segment at each end. The segments do not cross one another. It is two-dimensional.)
- “What does it mean to find the area of this polygon?” (It means finding the area of the region inside it.)
- “How can we find the area of this polygon?” (We can decompose the region inside it into triangles and rectangles.)

11.5 Triangulation

Cool Down: 5 minutes

This cool-down assesses students’ understanding of the defining characteristics of a polygon and the ways it can be decomposed.

Launch

Give students access to their geometry toolkits. Tell students that they need to show only how the area could be found; they do not have to actually calculate the area.

Student Task Statement

1. Here are two five-pointed stars. A student said, “Both shapes A and B are polygons. They are both composed of line segments and are two-dimensional. Neither have curves.” Do you agree with the statement? Explain your reasoning.

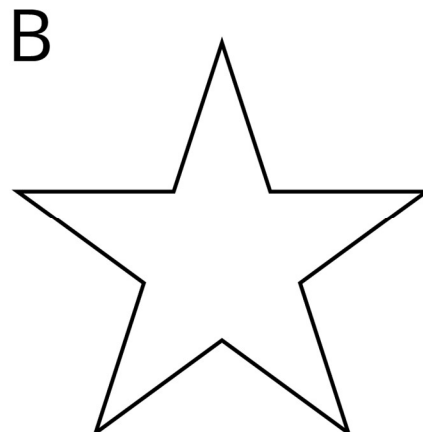
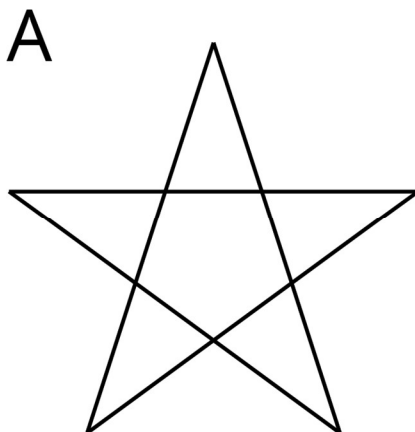

2. Here is a five-sided polygon. Describe or show the strategy you would use to find its area. Mark up and label the diagram to show your reasoning so that it can be followed by others. (It is not necessary to actually calculate the area.)

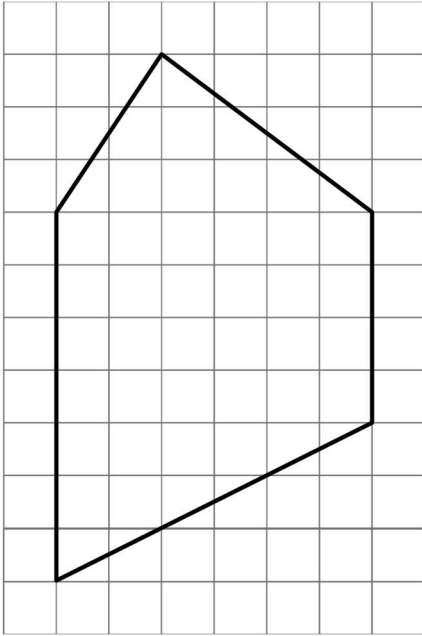

Student Response

1. Disagree. Only shape B is a polygon. Explanations vary. Sample explanation: Every segment in shape A meets or cross more than two segments at its ends, so it is not a polygon. Each segment in shape B meets only one other segment at each end.
2. Answers vary. Sample diagrams and responses:

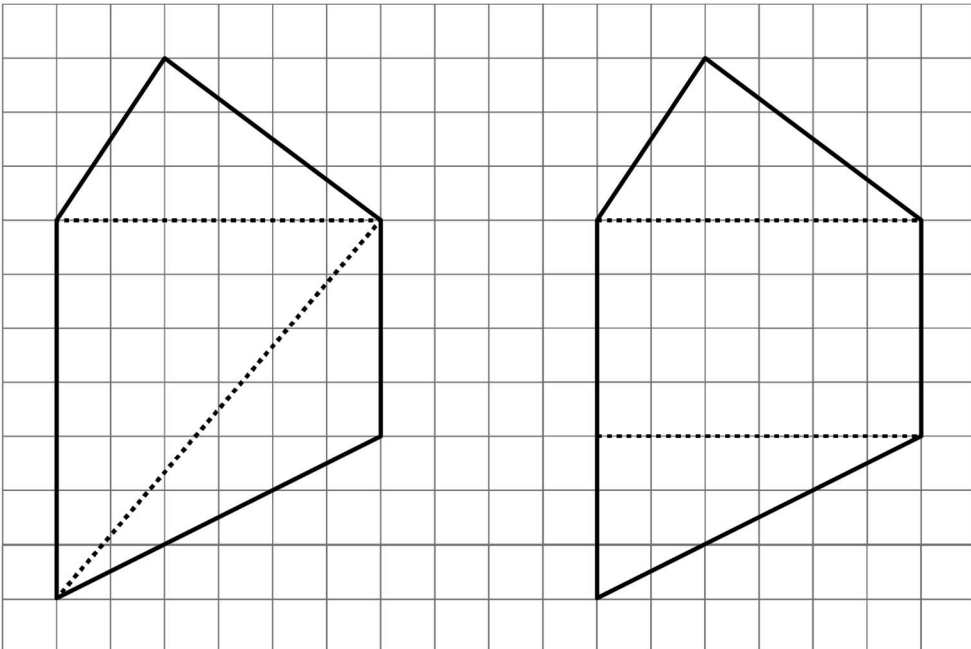

- The polygon can be decomposed into three triangles: one with a base of 6 units and a height of 3, a second one with a base of 7 and a height of 6, and a third with a base of 4 and a height of 6. All areas can be calculated using the area formula.
- The polygon can be decomposed into two triangles and a rectangle. One triangle has a base of 6 and a height 3, and the second has a base of 6 and a height of 1. Their areas can be calculated with the area formula. The rectangle is 6 by 4, so its area is the product of 6 and 4.

Student Lesson Summary

A **polygon** is a two-dimensional shape composed of straight line segments.

- Each end of a line segment connects to one other line segment. The point where two segments connect is a **vertex**. The plural of vertex is vertices.
- The segments are called the **edges** or **sides** of the polygon. The sides never cross each other. There are always an equal number of vertices and sides.

Here is a polygon with 5 sides. The vertices are labelled $A, B, C, D,$ and E .

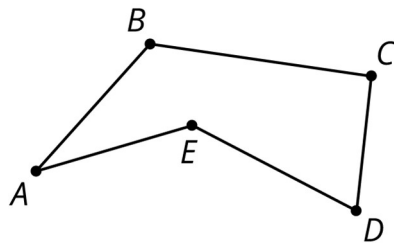

A polygon encloses a region. To find the area of a polygon is to find the area of the region inside it.

We can find the area of a polygon by decomposing the region inside it into triangles and rectangles.

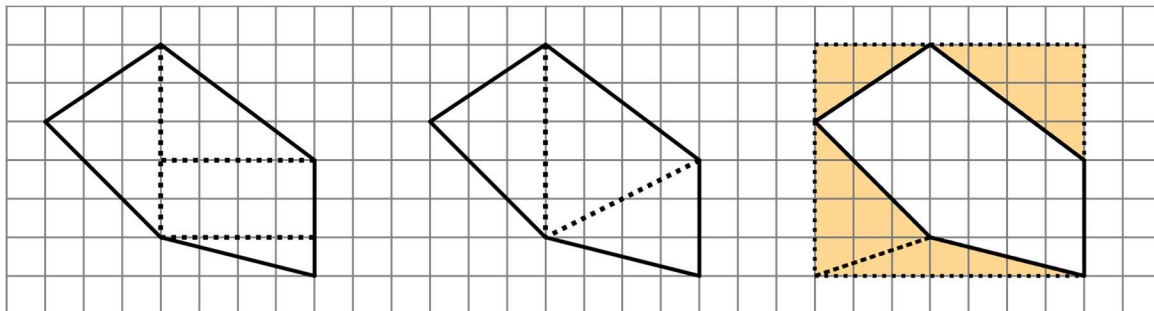

The first two diagrams show the polygon decomposed into triangles and rectangles; the sum of their areas is the area of the polygon. The last diagram shows the polygon enclosed with a rectangle; subtracting the areas of the triangles from the area of the rectangle gives us the area of the polygon.

Glossary

- polygon

Lesson 11 Practice Problems

1. Problem 1 Statement

Select **all** the polygons.

A

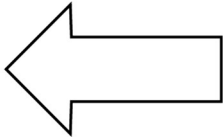

B



C



D

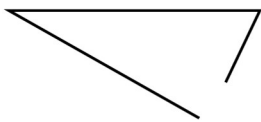

E



F

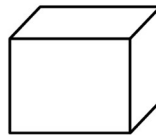

- a. A
- b. B
- c. C
- d. D
- e. E
- f. F

Solution ["A", "C"]

2. Problem 2 Statement

Mark each vertex with a large dot. How many edges and vertices does this polygon have?

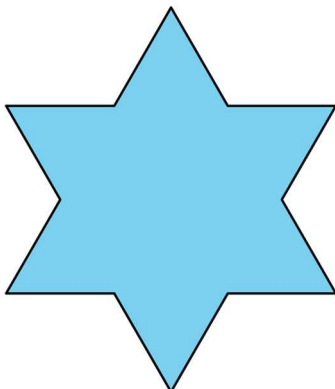

Solution

12 edges and 12 vertices

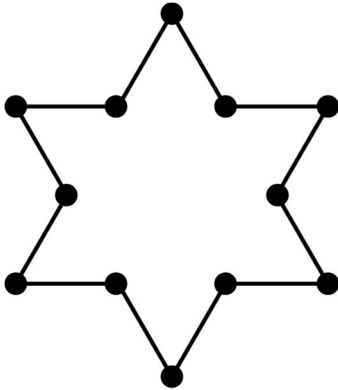

3. Problem 3 Statement

Find the area of this trapezium. Explain or show your strategy.

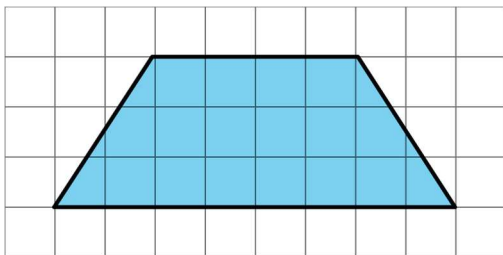

Solution

18 square units. Strategies vary. Possible strategy: Enclose the trapezium inside a 3-unit-by-8-unit rectangle. The area of the rectangle is 24 square units because $8 \times 3 = 24$. The area of each unshaded triangle within the rectangle is 3 square units because $(2 \times 3) \div 2 = 3$. The sum of areas of the two triangles is 6 square units. $24 - 6 = 18$, so the area of the trapezium is 18 square units.

4. Problem 4 Statement

Lin and Andre used different methods to find the area of a regular hexagon with 6-inch sides. Lin decomposed the hexagon into six identical, equilateral triangles. Andre decomposed the hexagon into a rectangle and two triangles.

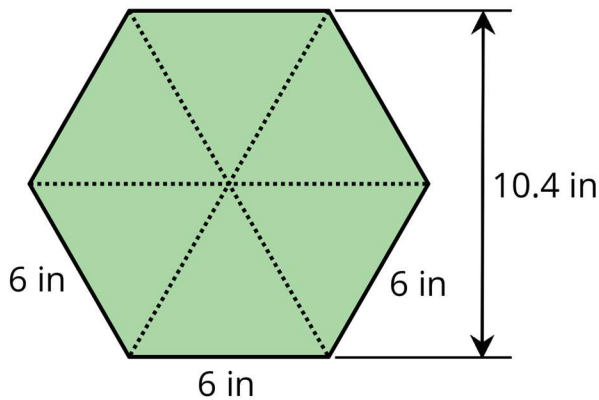

Lin's method

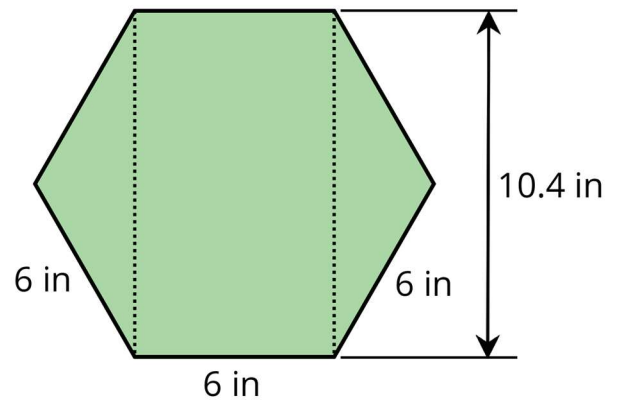

Andre's method

Find the area of the hexagon using each person's method. Show your reasoning.

Solution

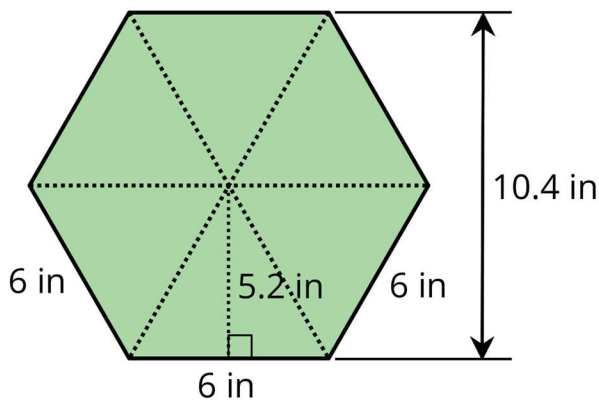

Lin's method

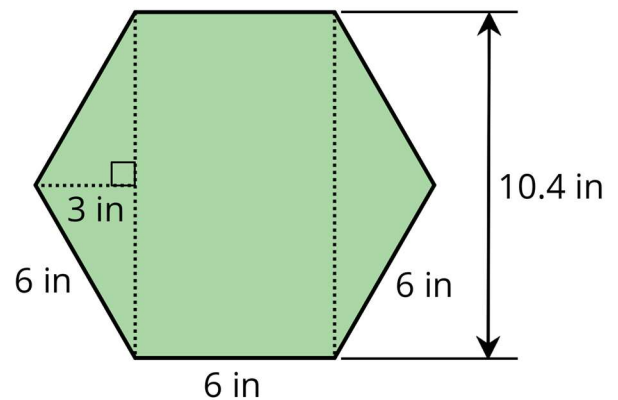

Andre's method

The height of each triangle in Lin's diagram is half of 10.4 inches or 5.2 inches. The area of each triangle is 15.6 square inches. $\frac{1}{2} \times 6 \times (5.2) = 15.6$. The hexagon is composed of 6 triangles, so its area is $6 \times (15.6)$ or 93.6 square inches.

The rectangle in Andre's diagram is $(10.4) \times 6$ or 62.4 square inches. Each triangle has a base of 10.4 inches and a height of 3 inches. (The horizontal distance across the middle of the hexagon is composed of two 6-inch segments. The vertical line that Andre drew cuts one 6-inch segment in half, so the segment on one side is 3 inches long.) The area of each triangle is $\frac{1}{2} \times 10.4 \times 3$ or 15.6 square inches. The area of the hexagon is therefore $62.4 + 15.6 + 15.6$ or 93.6 square inches.

5. Problem 5 Statement

- a. Identify a base and a corresponding height that can be used to find the area of this triangle. Label the base b and the corresponding height h .

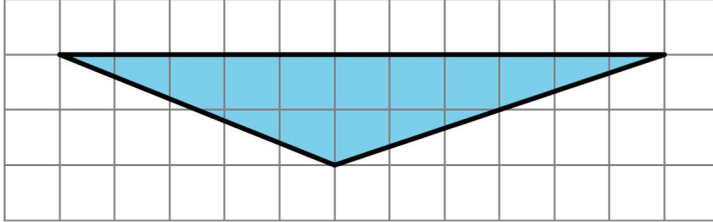

- b. Find the area of the triangle. Show your reasoning.

Solution

- a.

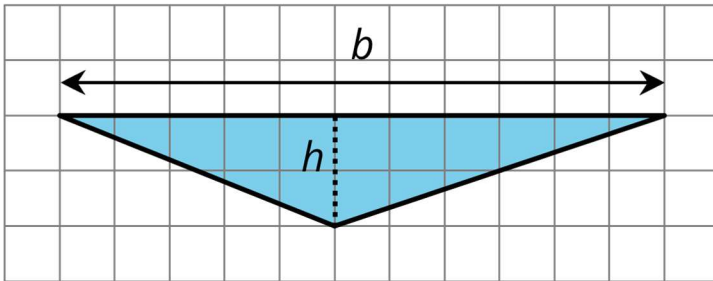

- b. 11 square units. $\frac{1}{2} \times 11 \times 2 = 11$.

6. Problem 6 Statement

On the grid, draw three different triangles with an area of 8 square units. Label the base and height of each triangle.

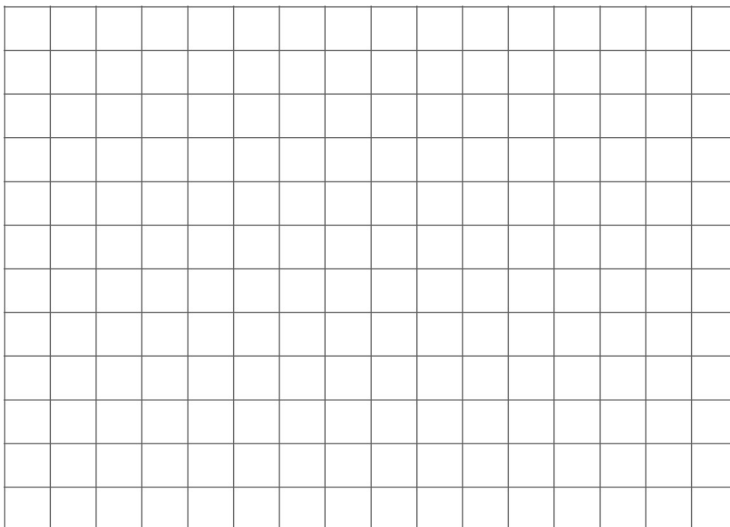

Solution

Answers vary. Drawings should show triangles with a base and a height that multiply to be 16 square units (i.e., each triangle is half of a parallelogram with an area of 16 square units).

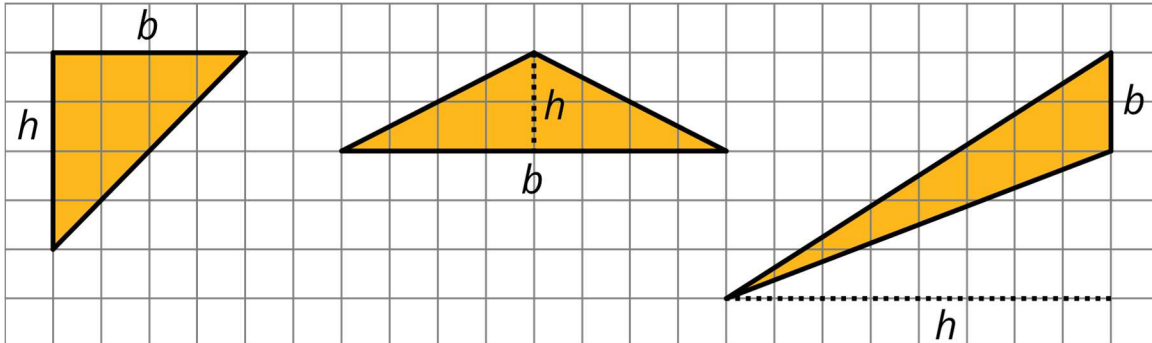

© These materials were derived and adapted from Illustrative Mathematics's IM 6–8 Math™. IM 6–8 Math was originally developed by Open Up Resources and authored by Illustrative Mathematics®, and is copyright 2017–2019 by Open Up Resources. It is licensed under the Creative Commons Attribution 4.0 International License (CC BY 4.0) <https://creativecommons.org/licenses/by/4.0/>. OUR's 6–8 Math Curriculum is available at <https://openupresources.org/math-curriculum/>. Adaptations and updates to IM 6–8 Math™ are copyright 2019 by Illustrative Mathematics®, and are licensed under the Creative Commons Attribution 4.0 International License (CC BY 4.0). Further adaptations have been made by MEI.