

## Lesson 13: Polyhedra

### Goals

- Compare and contrast (orally and in writing) features of prisms and pyramids.
- Comprehend and use the words “face”, “edge”, “vertex”, and “base” to describe polyhedra (in spoken and written language).
- Understand that the word “net” refers to a two-dimensional shape that can be assembled into a polyhedron, and create a net for a given polyhedron.

### Learning Targets

- I can describe the features of a polyhedron using mathematical vocabulary.
- I can explain the difference between prisms and pyramids.
- I understand the relationship between a polyhedron and its net.

### Lesson Narrative

In this lesson, students learn about **polyhedra** and their **nets**. They also study **prisms** and **pyramids** as types of polyhedra with certain defining features.

Polyhedra can be thought of as the three-dimensional analogue of polygons.

Here are some important aspects of polygons:

- They are made out of line segments called *edges*.
- Edges meet at a *vertex*.
- The edges only meet at vertices.
- Polygons always enclose a two-dimensional region.

Here is an analogous way to characterise polyhedra:

- They are made out of filled-in polygons called *faces*.
- Faces meet at an edge.
- The faces only meet at edges.
- Polyhedra always enclose a three-dimensional region.

Students do not need to memorise a formal definition of a polyhedron, but help them make sense of nets and surface area.

---

### Addressing

- Represent three-dimensional shapes using nets made up of rectangles and triangles, and use the nets to find the surface area of these shapes. Apply these techniques in the context of solving real-world and mathematical problems.

### Building Towards

- Represent three-dimensional shapes using nets made up of rectangles and triangles, and use the nets to find the surface area of these shapes. Apply these techniques in the context of solving real-world and mathematical problems.

### Instructional Routines

- Collect and Display
- Notice and Wonder

### Required Materials

#### Geometry toolkits

tracing paper, graph paper, coloured pencils, scissors, and an index card to use as a straightedge or to mark right angles.

#### Glue or glue sticks

#### Nets of polyhedral

#### Pre-assembled or commercially produced polyhedra

#### Scissors

#### Sticky tape

### 'What are polyhedra?'/Assembling polyhedra activity

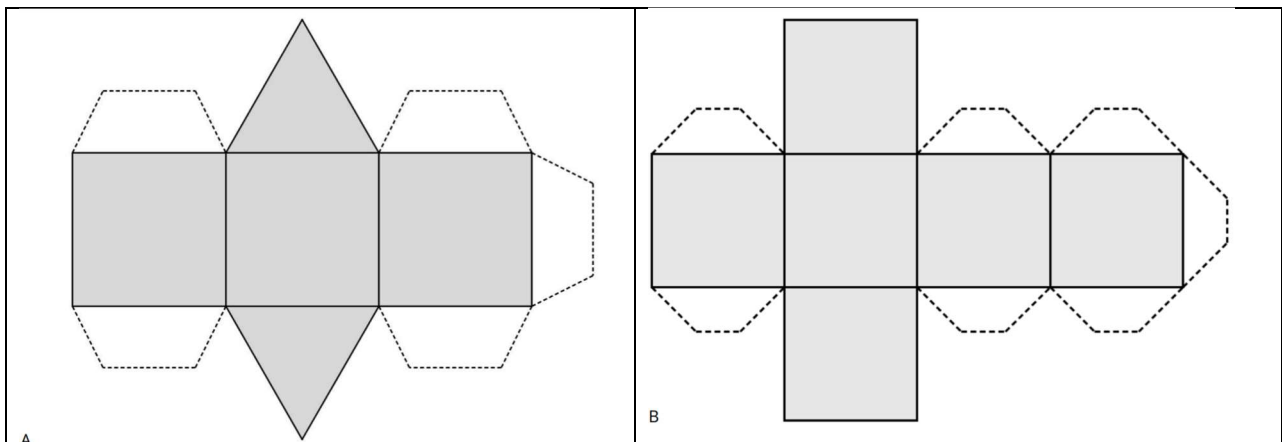

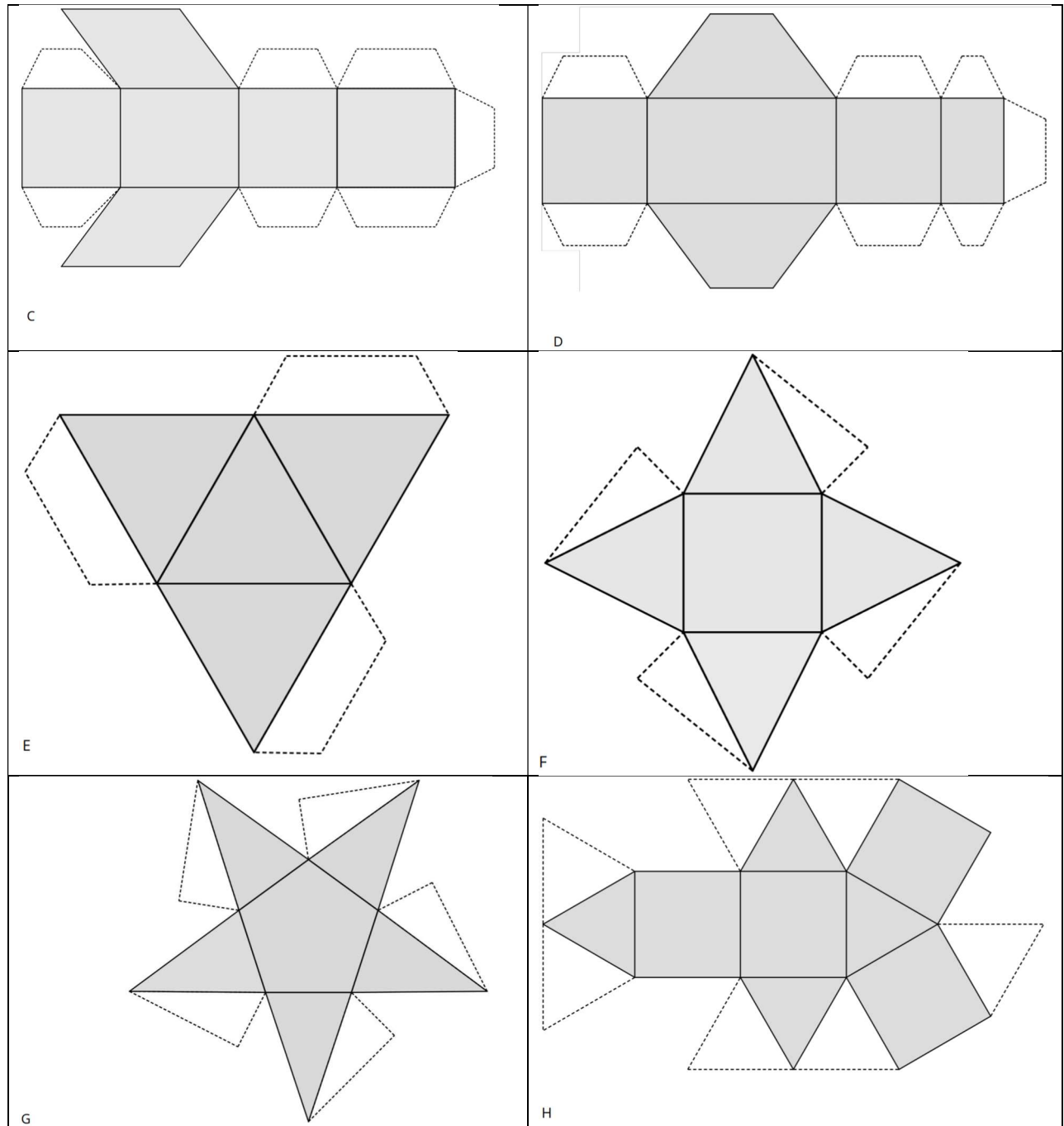

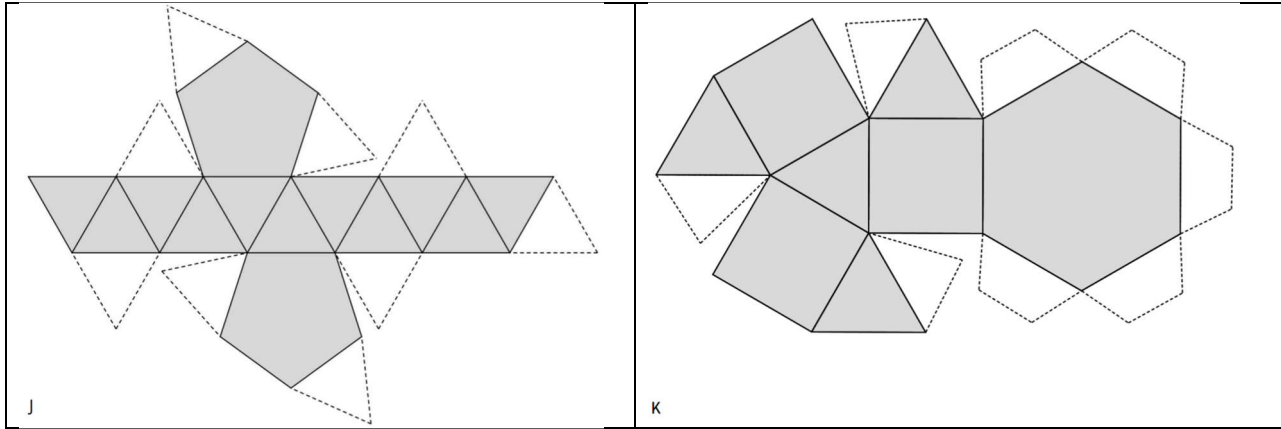

**Prisms and polyhedra activity**

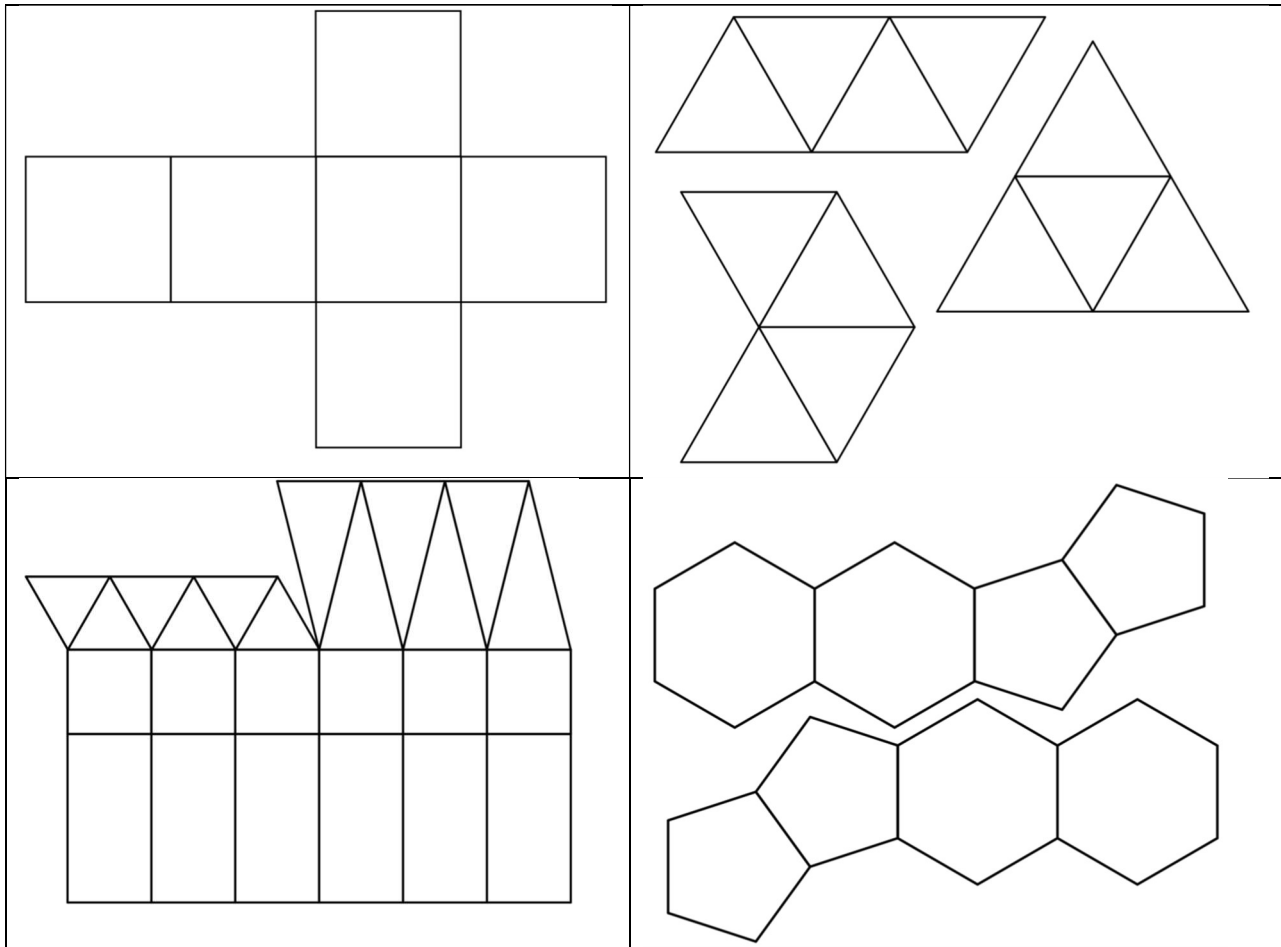

### Required Preparation

- Assemble collections of geometric shapes that each contains at least 2 familiar polyhedra, 2 unfamiliar polyhedra, and 2 non-polyhedra. Prepare one collection for each group of 3–4 students. If pre-made polyhedra are unavailable, assemble some from the nets in the blackline master for the warm-up.
- Print and pre-cut the nets and polygons in the blackline master for Prisms and Pyramids. Prepare 1 set per group of 3–4 students, along with sticky tape to join the polygons into a net.
- For the optional Assembling Polyhedra activity, print the nets from the same blackline master as for the warm-up. Prepare 2 copies of one net per student, and sticky tape or glue to assemble the net.

### Student Learning Goals

Let's investigate polyhedra.

## 13.1 What are Polyhedra?

### Warm Up: 10 minutes

In this warm-up, students analyse examples and counterexamples of polyhedra, observe their defining characteristics, and use their insights to sort objects into polyhedra and non-polyhedra. They then start developing a working definition of polyhedron.

Prepare physical examples of polyhedra and non-polyhedra for students to sort. These examples should be geometric shapes rather than real-world objects such as shoe boxes or canisters. If such shapes are not available, make some ahead of time using the nets in the blackline master.

As students work and discuss, notice those who can articulate defining features of a polyhedron. Invite them to share later.

### Instructional Routines

- Notice and Wonder

### Launch

Arrange students in groups of 3–4. Give students 1 minute of quiet time to study the examples and non-examples in the task statement. Ask them to be ready to share at least one thing they notice and one thing they wonder. Give the class a minute to share some of their observations and questions.

Next, give each group a physical set of three-dimensional shapes. The set should include some familiar polyhedra, some unfamiliar ones, and some non-polyhedra.

Ask groups to sort the shapes into polyhedra and non-polyhedra (the first question). If groups members disagree about whether a shape is a polyhedron, discuss the

disagreements. When the group has come to an agreement, give them 2–3 minutes of quiet time to complete the second question.

### Student Task Statement

Here are pictures that represent **polyhedra**:

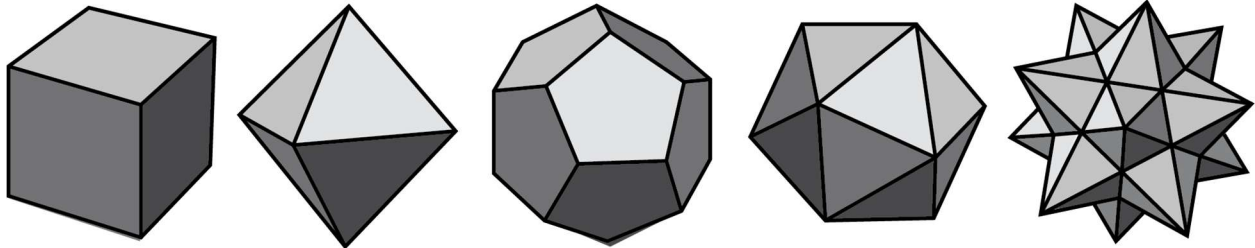

Here are pictures that do *not* represent polyhedra:

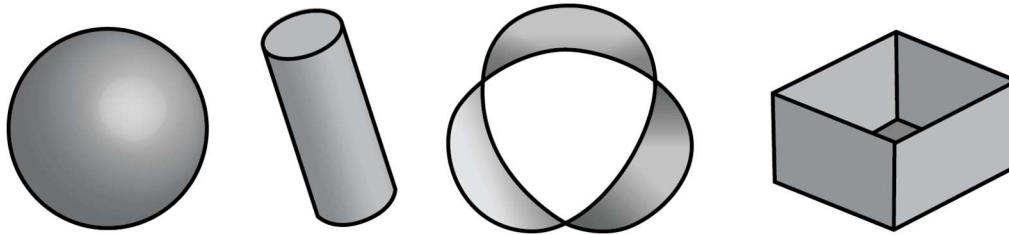

1. Your teacher will give you some shapes or objects. Sort them into polyhedra and non-polyhedra.
2. What features helped you distinguish the polyhedra from the other shapes?

### Student Response

1. No response required.
2. Answers vary. Sample responses:
  - Polyhedra are made from polygons.
  - Polyhedra don't have any unattached edges.
  - Non-polyhedra sometimes have curved or round surfaces.
  - Some non-polyhedra have a face that is not a polygon.

### Activity Synthesis

Invite students to share the features that they believe characterise polyhedra. Record their responses for all to see. For each one, ask the class if they agree or disagree. If they generally agree, ask if there is anything they would add or elaborate to make the

description clearer or more precise. If they disagree, ask for an explanation or a counterexample.

Students will have a chance to refine their definition of polyhedra later in the lesson—after exploring prisms and pyramids and learning about nets, so it is not important to compile a complete or precise set of descriptions or features.

Use a sample polyhedron or a diagram as shown here to introduce or reinforce the terminology surrounding polyhedra.

- The polygons that make up a polyhedron are called *faces*.
- The places where the sides of the faces meet are called **edges**.
- The “corners” are called **vertices**. (Clarify that the singular form is "vertex" and the plural form is "vertices.")

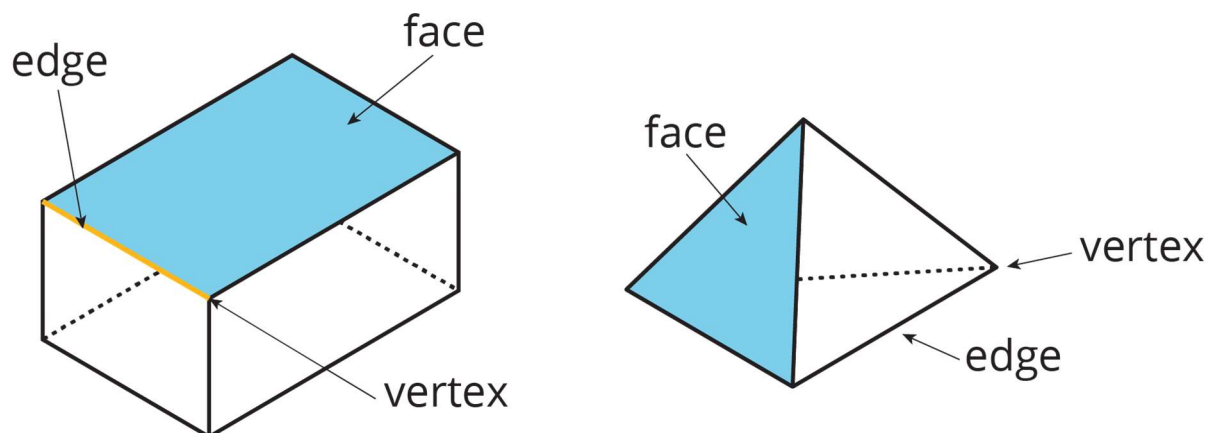

## 13.2 Prisms and Pyramids

**30 minutes**

This activity serves two goals: to uncover the defining features of **prisms** and **pyramids** as well as to introduce **nets** as two-dimensional representations of polyhedra.

Students first analyse prisms and pyramids and try to define their characteristics. Next, they learn about nets and think about the polygons needed to compose the nets of given prisms and pyramids. They then use their experience with the nets of prisms and pyramids to sharpen and refine their definitions of these polyhedra.

Ask students to discuss the features of prisms and pyramids, encourage them to use the terms face, edge, and vertex (vertices) in their descriptions.

### Instructional Routines

- Collect and Display

## Launch

Arrange students in groups of 3–4.

For the first question:

- Tell students that Polyhedra A–F are all prisms and Polyhedra P–S are all pyramids. (Display and pass around the prisms and pyramids in the task statement, if available.)
- Give students 2–3 minutes of quiet time for the first question and 2–3 minutes to discuss their observations in their groups. Ask them to pause for a class discussion before moving on.
- Solicit students' ideas about features that distinguish prisms and pyramids. Record students' responses in a two columns—one for prisms and the other for pyramids. It is not important that the lists are complete at this point.

Next, tell students that we are going to use nets to better understand prisms and pyramids. Explain that a **net** is a two-dimensional representation of a polyhedron.

Display a cube assembled from the net provided in the blackline master for the warm-up, as well as a cut-out of an unfolded net (consider removing the flaps). Demonstrate how the net with squares could be folded and assembled into a cube, or use this book of digital applets, <https://ggbm.at/rcu3Ka3j>, created in GeoGebra by the [GeoGebra DocuTeam](#). Point out how the number and the shape of the faces on the cube correspond to the number and the shape of the polygons in the net.

For the second question:

- Give groups a minute of quiet think time and a minute to discuss their response.
- To verify their answer, give each group one of the three nets from the first page of the blackline master. Ask them to try to assemble a triangular pyramid from their net.
- Invite groups to share with the class whether it can be done. Discuss why net 3 cannot be assembled into pyramid P (two of the triangles would overlap).

For the last question, tell students that they will create a net of another prism or pyramid:

- Assign each group a prism or a pyramid from the task statement (except for Prism B and pyramid P).
  - Give each group a set of pre-cut polygons from the last two pages of the blackline master.
  - Tell students to choose the right kind and number of polygons that make up their polyhedron. Then, arrange the polygons so that, when taped and folded, the arrangement is a net and could be assembled into their prism or pyramid. Encourage them to think of more than one net, if possible.
-



*Representation: Access for Perception.* Provide access to concrete manipulatives. Provide prisms and pyramids for students to view or manipulate. These hands-on models will help students identify characteristics or features, and support net building for each polyhedra.

*Supports accessibility for: Visual-spatial processing; Conceptual processing Speaking, Conversing: Collect and Display.* As students work on creating a net of their assigned polyhedron, circulate and listen to the language students use when talking about the polygons that make up their polyhedra, as well as the characteristics of their polyhedra (e.g., triangle, rectangle, square, hexagon, pentagon, vertex, edge, face). Collect this language, with corresponding drawings, and display it for all students to see. Remind students to borrow language from the display as they describe the features of prisms and pyramids. This will help students produce mathematical language to describe and define characteristics of polyhedra.

*Design Principle(s): Support sense-making*

### Student Task Statement

1. Here are some polyhedra called **prisms**.

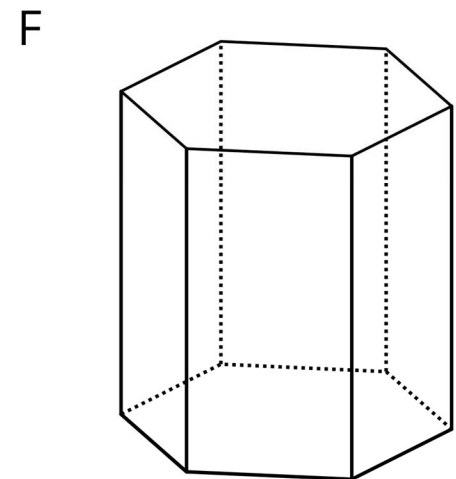
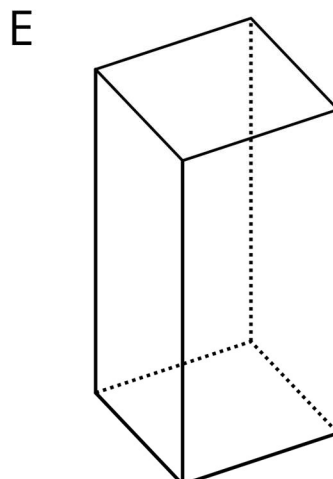
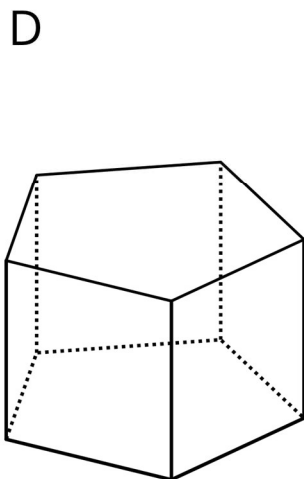
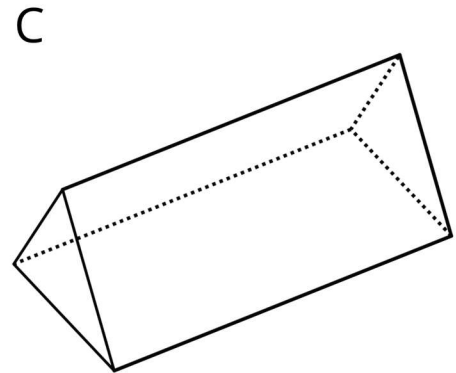
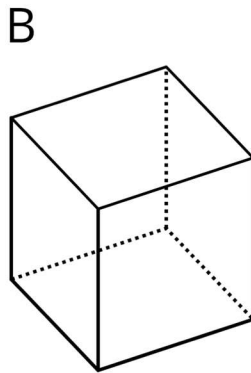
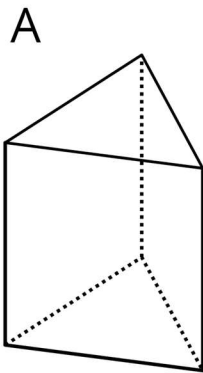

Here are some polyhedra called **pyramids**.

P

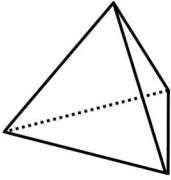

Q

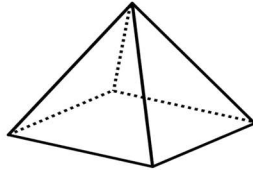

R

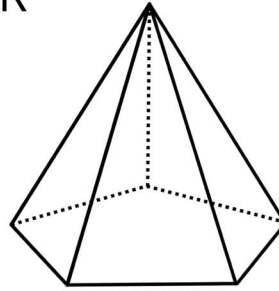

S

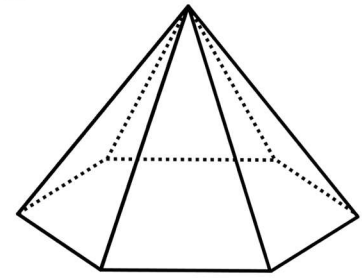

- a. Look at the prisms. What are their characteristics or features?
  - b. Look at the pyramids. What are their characteristics or features?
2. Which of these **nets** can be folded into pyramid P? Select all that apply.

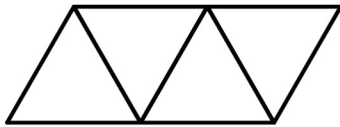

net 1

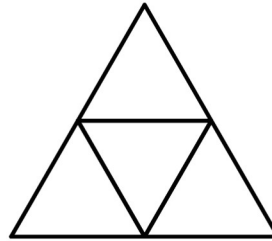

net 2

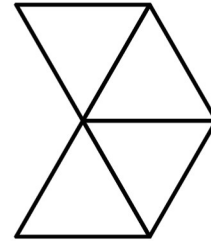

net 3

3. Your teacher will give your group a set of polygons and assign a polyhedron.
- a. Decide which polygons are needed to compose your assigned polyhedron. List the polygons and how many of each are needed.
  - b. Arrange the cut-outs into a net that, if taped and folded, can be assembled into the polyhedron. Sketch the net. If possible, find more than one way to arrange the polygons (show a different net for the same polyhedron).

### Student Response

1. Answers vary. Sample responses:
  - a. A prism has rectangular faces. Some of the faces are parallel to one another. A prism may have two faces that are not rectangles.
  - b. A pyramid has a triangle for all or all but one of its faces. That one face might be a different polygon, and all triangles share an edge with it. All triangles also meet at a single vertex.
2. Nets 1 and 2 can be assembled into pyramid P, but net 3 cannot.
  - a. Answers vary. Possible responses:

Prism A: 2 triangles, 3 squares  
Prism C: 2 triangles, 3 rectangles  
Prism D: 2 pentagons, 5 rectangles  
Prism E: 2 squares, 4 rectangles  
Prism F: 2 hexagons, 6 rectangles  
Pyramid Q: 1 square, 4 triangles  
Pyramid R: 1 pentagon, 5 triangles  
Pyramid S: 1 hexagon, 6 triangles

b. Drawings vary.

### Are You Ready for More?

What is the smallest number of faces a polyhedron can possibly have? Explain how you know.

### Student Response

Four faces (a triangular pyramid, also known as a tetrahedron). Explanations vary. Sample explanation: The triangle is the polygon with the fewest number of sides. If there is one triangular face, there must be another polygon attached at each edge of it, so it is impossible to use fewer than four faces. It is possible to create a polyhedron with four triangle faces. (Pyramid P in this activity is an example.)

### Activity Synthesis

Select groups to share their arrangements of polygons. If time permits and if possible, have students tape their polygons and fold the net to verify that it could be assembled into the intended polyhedron. Discuss:

- “What do the nets of prisms have in common?” (They all have rectangles. They have a pair of polygons that may not be rectangles.)
- “What do the nets of pyramids have in common?” (They all have triangles. They have one polygon that may not be a triangle.)
- “Is there only one possible net for a prism or a pyramid?” (No, the polygons can be arranged in different ways and still be assembled into the same prism or pyramid.)

Explain the following points about prisms and pyramids:

- A prism has two parallel, identical faces called **bases** and a set of rectangles connecting the bases.
- Prisms are named for the shape of the bases. For example, if the base of a prism is a pentagon, then the prism is called a “pentagonal prism.”

- A pyramid has one face called the base that can be any polygon and a set of faces that are all triangles. Each edge of the base is shared with an edge of a triangle. All of these triangles meet at a single vertex.
- Pyramids are named for the shape of their base. For example, if the base of a pyramid is a square, then the pyramid is called a “square pyramid.”

### 13.3 Assembling Polyhedra

#### Optional: 20 minutes

This optional activity gives students the experience of assembling polyhedra from nets. Counting the vertices, edges, and faces of a polyhedra helps to reinforce their understanding of the vocabulary. You will need the same blackline master as the one provided for the warm-up.

Students are likely to need assistance in assembling their polyhedra. Circulate and support students as needed.

#### Launch

Tell the class that they are going to assemble polyhedra from nets. Point out that the net has shaded and unshaded polygons. Display an example and explain that only the shaded polygons in the nets will show once the net is assembled. The unshaded polygons are “flaps” to make it easier to glue or tape the polygons together; they will get tucked behind the shaded polygons and are not really part of the polyhedron. Tell students that creasing along all of the lines first will make it easier to fold the net up and attach the various polygons together. A straightedge can be very helpful for making the creases.

Give each student two copies of a net so they can compare the assembled version with the unfolded net. Provide access to geometry toolkits and glue or sticky tape. Ask students to build their shapes and complete the question, and then to discuss their responses with another student with the same polyhedron.

#### Anticipated Misconceptions

Students may have trouble getting an accurate count of faces, edges, and vertices. Suggest that they set the shape on the table and then separately count the amount on the top, bottom, and lateral sides of the shape. Or recommend that they label each face with a number or a name and keep track of the parts associated with each face, taking care not to double count edges and vertices.

#### Student Task Statement

1. Your teacher will give you the net of a polyhedron. Cut out the net, and fold it along the edges to assemble a polyhedron. Tape or glue the flaps so that there are no unjoined edges.
2. How many **vertices**, **edges**, and **faces** are in your polyhedron?

---

## Student Response

1. No answer required.
2. Answers vary. Possible responses:
  - A: 6 vertices, 9 edges, 5 faces
  - B: 8 vertices, 12 edges, 6 faces
  - C: 8 vertices, 12 edges, 6 faces
  - D: 8 vertices, 12 edges, 6 faces
  - E: 4 vertices, 6 edges, 4 faces
  - F: 5 vertices, 8 edges, 5 faces
  - G: 6 vertices, 10 edges, 6 faces
  - H: 8 vertices, 14 edges, 8 faces
  - J: 10 vertices, 20 edges, 12 faces
  - K: 9 vertices, 15 edges, 8 faces

## Activity Synthesis

After students have conferred with another student and agreed on the number of vertices, edges, and faces of their polyhedron, tell the class they will now share their completed polyhedra and the unfolded version of the net with the class. Consider either asking students to pass their two items around, or to leave their the polyhedra and nets displayed while students circulate around the room to view others' work.

*Representation: Develop Language and Symbols.* Create a display of important terms and vocabulary. Invite students to suggest language or diagrams to include that will support their understanding and memory. Include the following terms and maintain the display for reference throughout the unit: polyhedra, prism, pyramid, face, edge, vertices, and net.  
*Supports accessibility for: Conceptual processing; Language; Memory*

## Lesson Synthesis

Review the features of prisms and pyramids by selecting 1–2 polyhedra used in the warm-up. Ask students to explain (using the terminology they learned, if possible) why each one is or is not a prism or a pyramid. If it is a prism or pyramid, ask students to name it.

Revisit the working definition of polyhedra generated earlier in the lesson and ask students to see if or how it might be refined. Ask if there is anything they should add, remove, or adjust given their work with prisms, pyramids, and nets.

Highlight the following points about polyhedra. Ask students to illustrate each point using a shape or a net.

- A **polyhedron** is a three-dimensional shape built from filled-in polygons. We call the polygons *faces*. (The plural of polyhedron is polyhedra.)
- All *edges* of polygons meet another polygon along a complete edge.
- Each polygon meets one and only one polygon on each of the edges.

- The polygons enclose a three-dimensional region.

Consider displaying in a visible place the key ideas from students' list and from this discussion so that they can serve as a reference later.

## 13.4 Three-Dimensional Shapes

**Cool Down: 5 minutes**

### Anticipated Misconceptions

Some students may mistake a triangular prism (especially one that is not sitting on one of its bases) as a pyramid because it has triangular faces.

### Student Task Statement

1. Write your best definition or description of a polyhedron. If possible, use the terms you learned in this lesson.
2. Which of these five polyhedra are prisms? Which are pyramids?

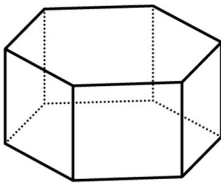

A

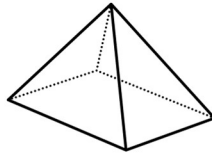

B

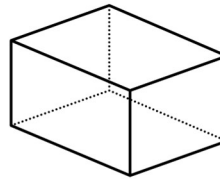

C

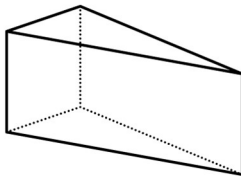

D

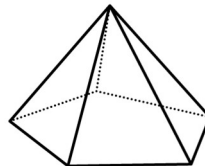

E

### Student Response

1. Answers vary but might include one or more of these elements: A polyhedron is a three-dimensional shape made from faces that are filled-in polygons. Each face meets one and only one other face along a complete edge. The points where edges meet are called vertices.
2. A, C, and D are prisms. B and E are pyramids.

### Student Lesson Summary

A **polyhedron** is a three-dimensional shape composed of faces. Each face is a filled-in polygon and meets only one other face along a complete edge. The ends of the edges meet at points that are called vertices.

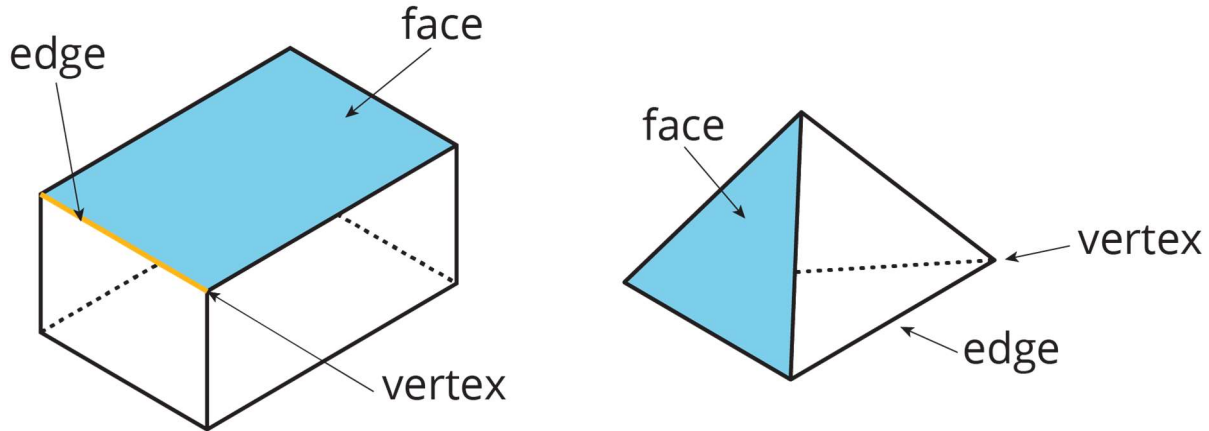

A polyhedron always encloses a three-dimensional region.

The plural of polyhedron is polyhedra. Here are some drawings of polyhedra:

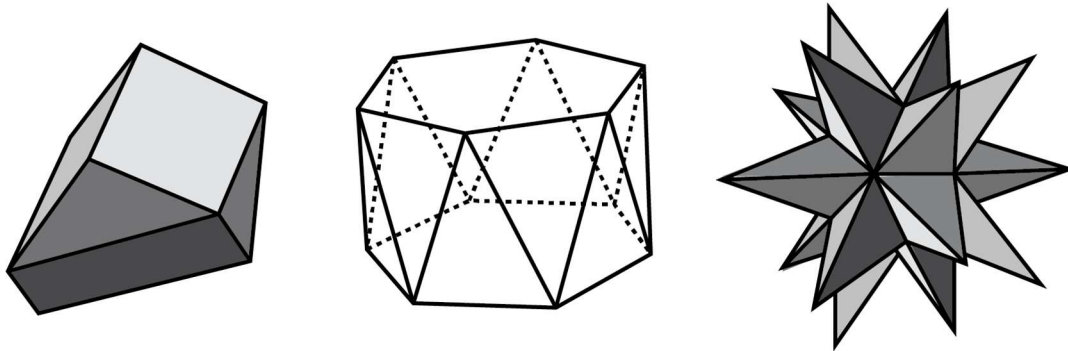

A **prism** is a type of polyhedron with two identical faces that are parallel to each other and that are called **bases**. The bases are connected by a set of rectangles (or sometimes parallelograms).

A prism is named for the shape of its bases. For example, if the base is a pentagon, then it is called a “pentagonal prism.”

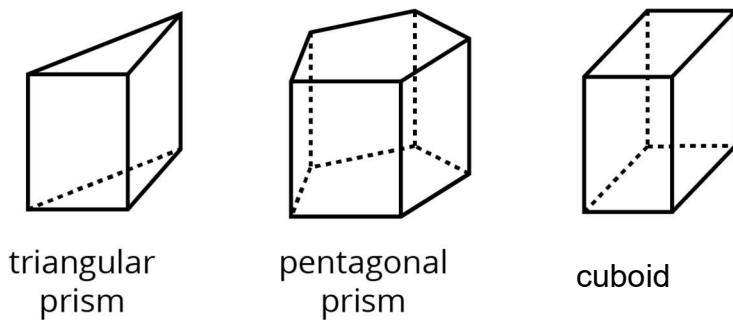

A cuboid is a rectangular prism.

A **pyramid** is a type of polyhedron that has one special face called the base. All of the other faces are triangles that all meet at a single vertex.

A pyramid is named for the shape of its base. For example, if the base is a pentagon, then it is called a “pentagonal pyramid.”

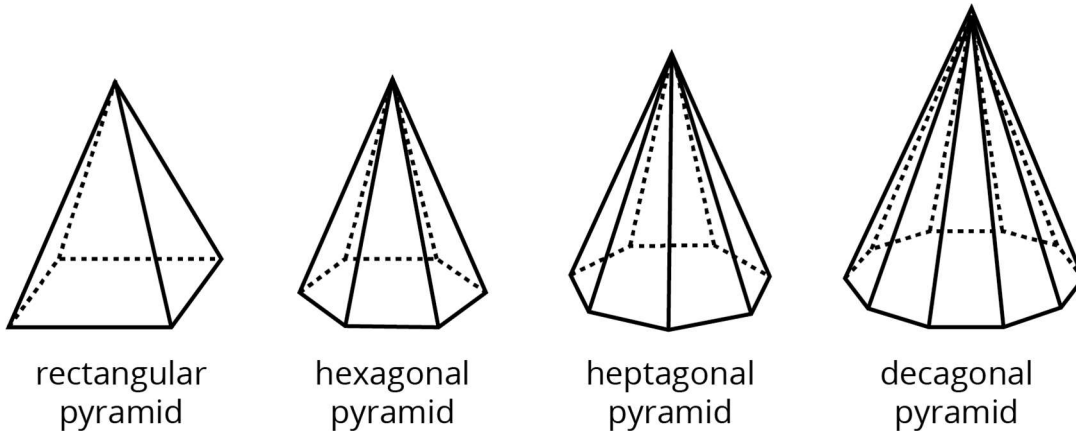

A **net** is a two-dimensional representation of a polyhedron. It is composed of polygons that form the faces of a polyhedron.

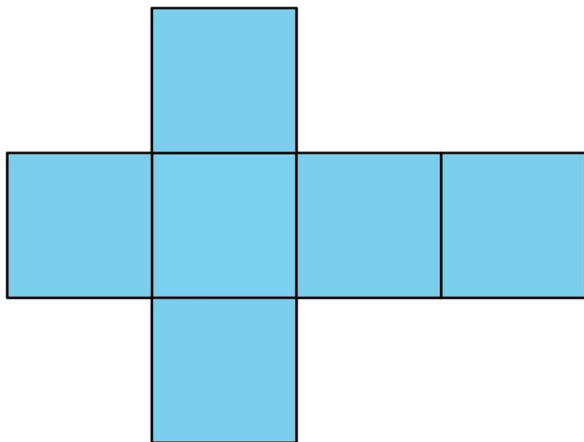

A cube has 6 square faces, so its net is composed of six squares, as shown here.

A net can be cut out and folded to make a model of the polyhedron.

In a cube, every face shares its edges with 4 other squares. In a net of a cube, not all edges of the squares are joined with another edge. When the net is folded, however, each of these open edges will join another edge.

It takes practice to visualise the final polyhedron by just looking at a net.

### Glossary

- base (of a prism or pyramid)
- net



- polyhedron
- prism
- pyramid

### Lesson 13 Practice Problems

#### 1. Problem 1 Statement

Select **all** the polyhedra.

A

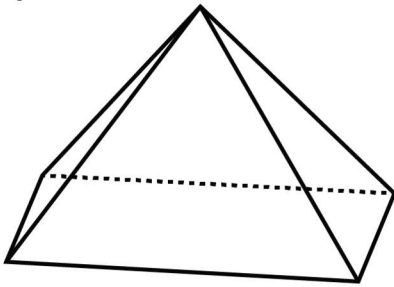

B

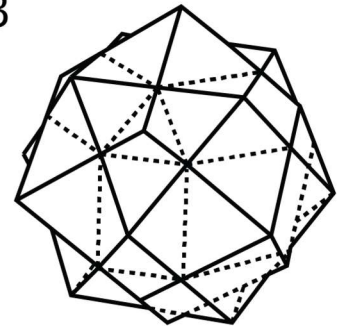

C

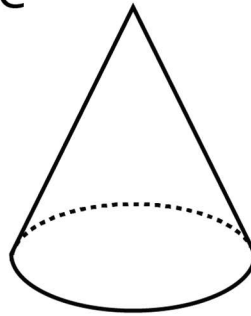

D

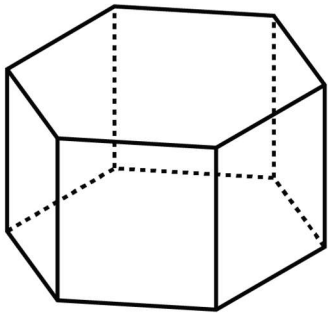

E

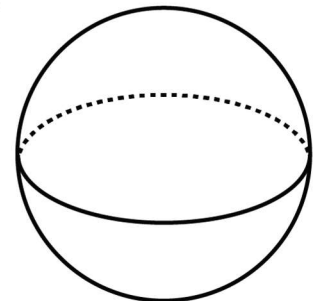

- a. A
- b. B
- c. C
- d. D
- e. E

**Solution** ["A", "B", "D"]

**2. Problem 2 Statement**

- a. Is this polyhedron a prism, a pyramid, or neither? Explain how you know.

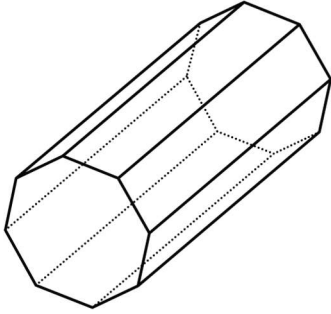

- b. How many faces, edges, and vertices does it have?

**Solution**

- a. Prism. It has two parallel octagonal bases that match up exactly.  
b. 10 faces, 24 edges, 16 vertices

**3. Problem 3 Statement**

Tyler said this net cannot be a net for a square prism because not all the faces are squares.

Do you agree with Tyler? Explain your reasoning.

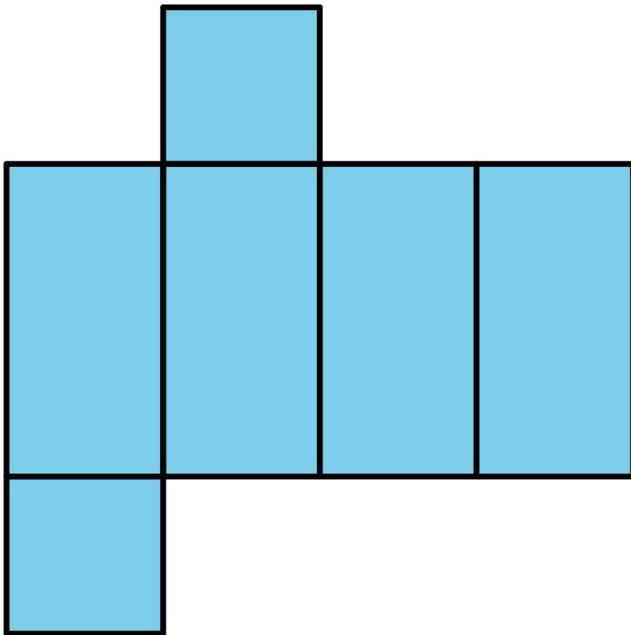

**Solution**

---

Disagree. Sample reasoning: A square prism must have two bases that are squares, but the other faces can be non-square rectangles. There are two squares in the net, and the net can be folded into a square prism.

**4. Problem 4 Statement**

Explain why each of these triangles has an area of 9 square units.

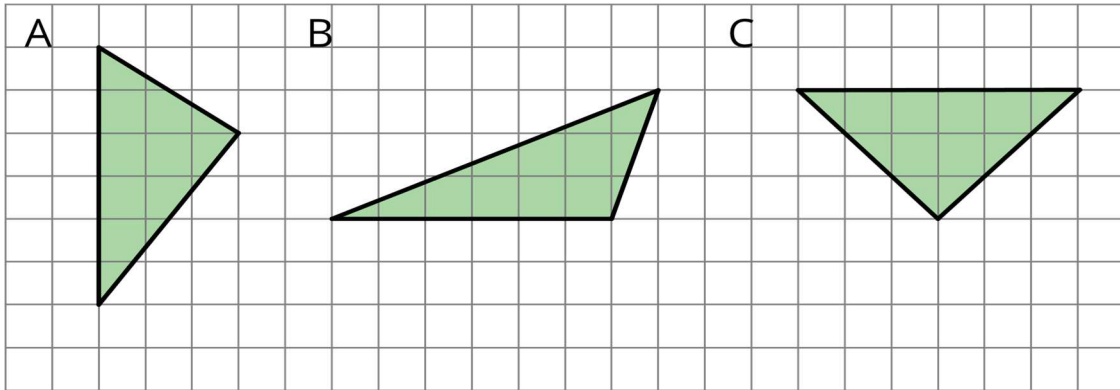

**Solution**

Answers vary. Sample explanation: Each triangle is half of a parallelogram with an area of 18 square units (i.e., with a base of 6 units and a height of 3 units), as shown in these diagrams.

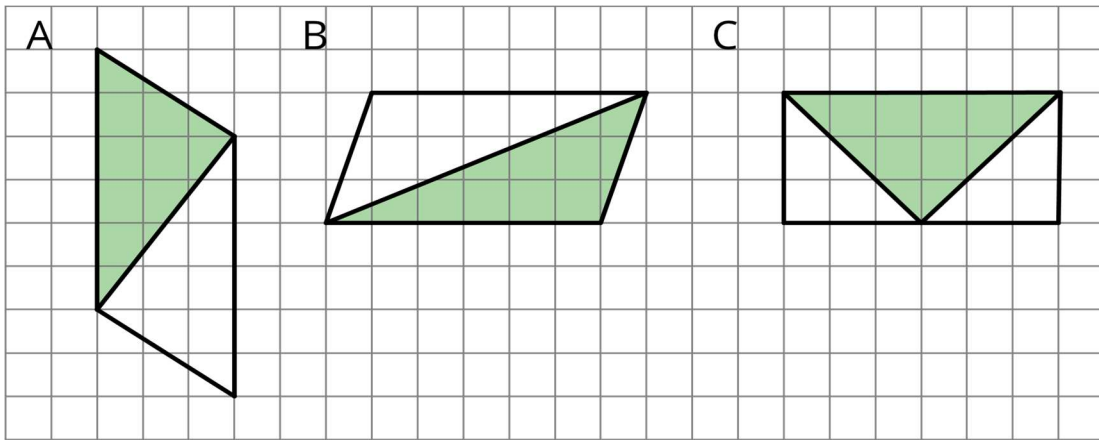

**5. Problem 5 Statement**

- a. A parallelogram has a base of 12 metres and a height of 1.5 metres. What is its area?
- b. A triangle has a base of 16 inches and a height of  $\frac{1}{8}$  inches. What is its area?
- c. A parallelogram has an area of 28 square feet and a height of 4 feet. What is its base?

- d. A triangle has an area of 32 square millimetres and a base of 8 millimetres. What is its height?

**Solution**

- a. 18 square metres
- b. 1 square inch
- c. 7 feet
- d. 8 millimetres

**6. Problem 6 Statement**

Find the area of the shaded region. Show or explain your reasoning.

E

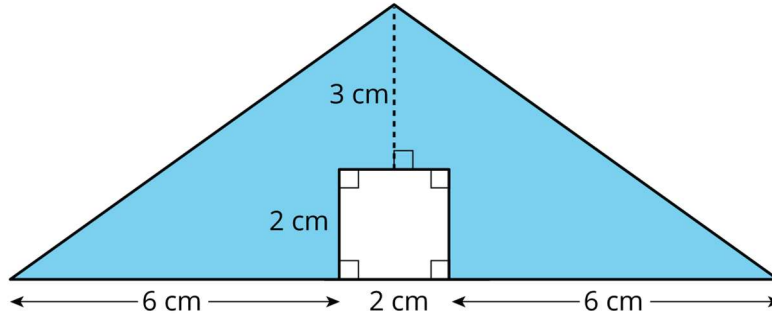

**Solution**

31 cm<sup>2</sup>. Sample reasoning: The two right-angled triangles can be put together to make a 7 cm-by-5 cm rectangle whose area is 35 cm<sup>2</sup>. However, a 2 cm-by-2 cm square is removed. The shaded area is 31 cm<sup>2</sup>.



© These materials were derived and adapted from Illustrative Mathematics's IM 6–8 Math™. IM 6–8 Math was originally developed by Open Up Resources and authored by Illustrative Mathematics®, and is copyright 2017–2019 by Open Up Resources. It is licensed under the Creative Commons Attribution 4.0 International License (CC BY 4.0) <https://creativecommons.org/licenses/by/4.0/>. OUR's 6–8 Math Curriculum is available at <https://openupresources.org/math-curriculum/>. Adaptations and updates to IM 6–8 Math™ are copyright 2019 by Illustrative Mathematics®, and are licensed under the Creative Commons Attribution 4.0 International License (CC BY 4.0). Further adaptations have been made by MEI.