Lesson 8: Reasoning about solving equations (Part 2)

Goals

- Compare and contrast (orally) different strategies for solving an equation of the form $p(x + q) = r$.
- Explain (orally and in writing) how to use a balanced balance diagram to solve an equation of the form $p(x + q) = r$.
- Interpret a balanced balance diagram with multiple groups, and justify (in writing) that there is more than one way to write an equation that represents the relationship shown.

Learning Targets

- I can explain how a balanced balance and an equation represent the same situation.
- I can explain why some balanced balances can be described by two different equations, one with parentheses and one without.
- I can find an unknown weight on a balance diagram and solve an equation that represents the diagram.
- I can write an equation that describes the weights on a balanced balance.

Lesson Narrative

This lesson continues the work of developing efficient equation solving strategies, justified by working with balance diagrams. The goal of this lesson is for students to understand two different ways to solve an equation of the form $p(x + q) = r$ efficiently. After a warm-up to revisit the distributive property, the first activity asks students to explain why either of two equations could represent a diagram and reason about a solution. The next activity presents four diagrams, asks students to match equations and then solve them. The goal is for students to see and understand two approaches to solving this type of equation.

Building On

- Identify when two expressions are equivalent (i.e., when the two expressions name the same number regardless of which value is substituted into them). For example, the expressions $y + y + y$ and $3y$ are equivalent because they name the same number regardless of which number y stands for.

Addressing

- Solve word problems leading to equations of the form $px + q = r$ and $p(x + q) = r$, where p , q , and r are specific rational numbers. Solve equations of these forms fluently. Compare an algebraic solution to an arithmetic solution, identifying the sequence of the operations used in each approach. For example, the perimeter of a rectangle is 54 cm. Its length is 6 cm. What is its width?

Instructional Routines

- Stronger and Clearer Each Time
- Compare and Connect
- Think Pair Share

Student Learning Goals

Let's use balances to understand two different ways of solving equations with parentheses.

8.1 Equivalent to $2(x + 3)$

Warm Up: 5 minutes

Students worked with the distributive property with variables in an earlier unit and with numbers in earlier years. In order to understand the two ways of solving an equation of the form $p(x + q) = r$ in the upcoming lessons, it is helpful to have some fluency with the distributive property.

Instructional Routines

- Think Pair Share

Launch

Arrange students in groups of 2. Give 3 minutes of quiet work time and then invite students to share their responses with their partner, followed by a whole-class discussion.

Student Task Statement

Select **all** the expressions equivalent to $2(x + 3)$.

1. $2 \times (x + 3)$
2. $(x + 3)2$
3. $2 \times x + 2 \times 3$
4. $2 \times x + 3$
5. $(2 \times x) + 3$
6. $(2 + x)3$

Student Response

1, 2, 3

Activity Synthesis

Focus specifically on why 1 and 3 are equivalent to lead into the next activity. You may also recall the warm-ups from prior lessons and ask if $2(x + 3)$ is equal to 10, or other numbers, how much is $x + 3$?

Ask students to write another expression that is equivalent to $2(x + 3)$ (look for $2x + 6$).

8.2 Either Or

15 minutes

This activity continues the work of using a balanced balance to develop strategies for solving equations. Students are presented with a balanced balance and are asked to explain why each of two different equations could represent it. They are then asked to find the unknown weight. Note that no particular solution method is prescribed. Give students a chance to come up with a reasonable approach, and then use the synthesis to draw connections between the diagram and each of the two equations. Students notice the structure of equations and diagrams and find correspondences between them and between solution strategies.

Instructional Routines

- Stronger and Clearer Each Time
- Think Pair Share

Launch

Keep students in the same groups. Give 5–10 minutes of quiet work time and time to share their responses with a partner, followed by a whole-class discussion.

Representation: Develop Language and Symbols. Use virtual or concrete manipulatives to connect symbols to concrete objects or values. For example, create a balanced balance using concrete objects. Be sure to use individual pieces for each part of the diagram. Demonstrate moving pieces off of the balance to create an equation. Invite students to show different ways to create the same equation.

Supports accessibility for: Visual-spatial processing; Conceptual processing *Conversing, Representing: Stronger and Clearer Each Time.* Use this routine to help students improve their written response to the first question, by providing them with multiple opportunities to clarify their explanations through conversation. Give students time to meet with 2–3 partners, to share and get feedback on their responses. Provide listeners with prompts for feedback that will help their partners strengthen their ideas and clarify their language. For example, students can ask their partner, "How is $2(x + 3)$ represented in the balance?" or "Can you say more about..." After both students have shared and received feedback, provide students with 3–4 minutes to revise their initial draft, including ideas and language from their partner. This will help students communicate why the same balance can be represented with equations in either form.

Design Principle(s): Optimise output (for explanation); Cultivate conversation

Student Task Statement

1. Explain why either of these equations could represent this balance:

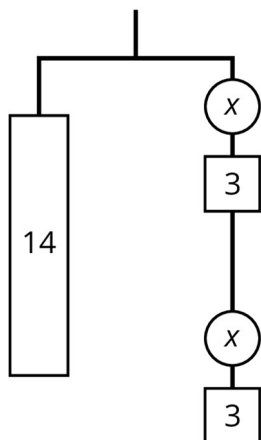

$$14 = 2(x + 3) \text{ or } 14 = 2x + 6$$

2. Find the weight of one circle. Be prepared to explain your reasoning.

Student Response

1. Answers vary. The diagram shows 14 balanced with 2 groups of $x + 3$, and this corresponds to $14 = 2(x + 3)$. The diagram also shows 14 balanced with 2 x 's and another 6 units of weight, which corresponds to $14 = 2x + 6$.
2. 4 units. Sample reasoning:
 - Since 2 groups of $x + 3$ weighs 14 units, 1 group must weigh 7 units. If $x + 3 = 7$, then $x = 4$.
 - Remove 6 units from each side, leaving $8 = 2x$. Therefore, $x = 4$.

Activity Synthesis

Have one student present who did $7 = x + 3$ first, and another student present who subtracted 6 first. If no one mentions one of these approaches, demonstrate it. Show how the balance supports either approach. The finished work might look like this for the first equation:

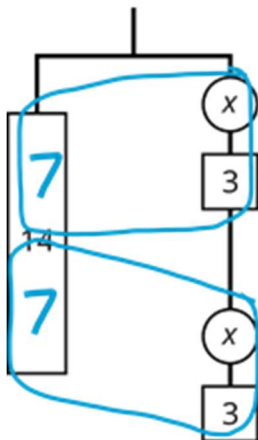

$$\begin{aligned} 14 &= 2(x + 3) \\ 7 &= x + 3 \end{aligned}$$

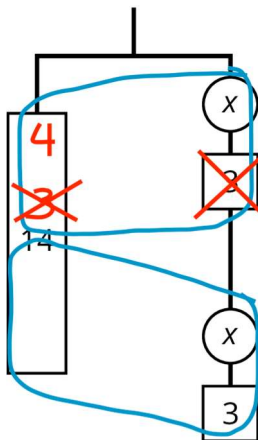

$$\begin{aligned} 7 &= x + 3 \\ 4 &= x \end{aligned}$$

For the second equation, rearrange the right side of the balance, first, so that 2 x 's are on the top and 6 units of weight are on the bottom. Then, cross off 6 from each side and divide each side by 2. Show this side by side with “doing the same thing to each side” of the equation.

8.3 Use Balances to Understand Equation Solving, Again

15 minutes

The first question is straightforward since each diagram uses a different letter, but it's there to make sure students start with $p(x + q) = r$. If some want to rewrite as $px + pq = r$ first, that's great. We want some to do that but others to divide both sides by p first. Monitor for students who take each approach.

Instructional Routines

- Compare and Connect

- Think Pair Share

Launch

Keep students in the same groups. Give 5–10 minutes of quiet work time and time to share their responses with a partner, followed by a whole-class discussion.

Action and Expression: Internalise Executive Functions. To support development of organisational skills in problem-solving, chunk this task into more manageable parts. For example, show only 2 balances and 2 equations. If students finish early, assign the remaining balances and equations.

Supports accessibility for: Memory; Organisation

Student Task Statement

Here are some balanced balances. Each piece is labelled with its weight.

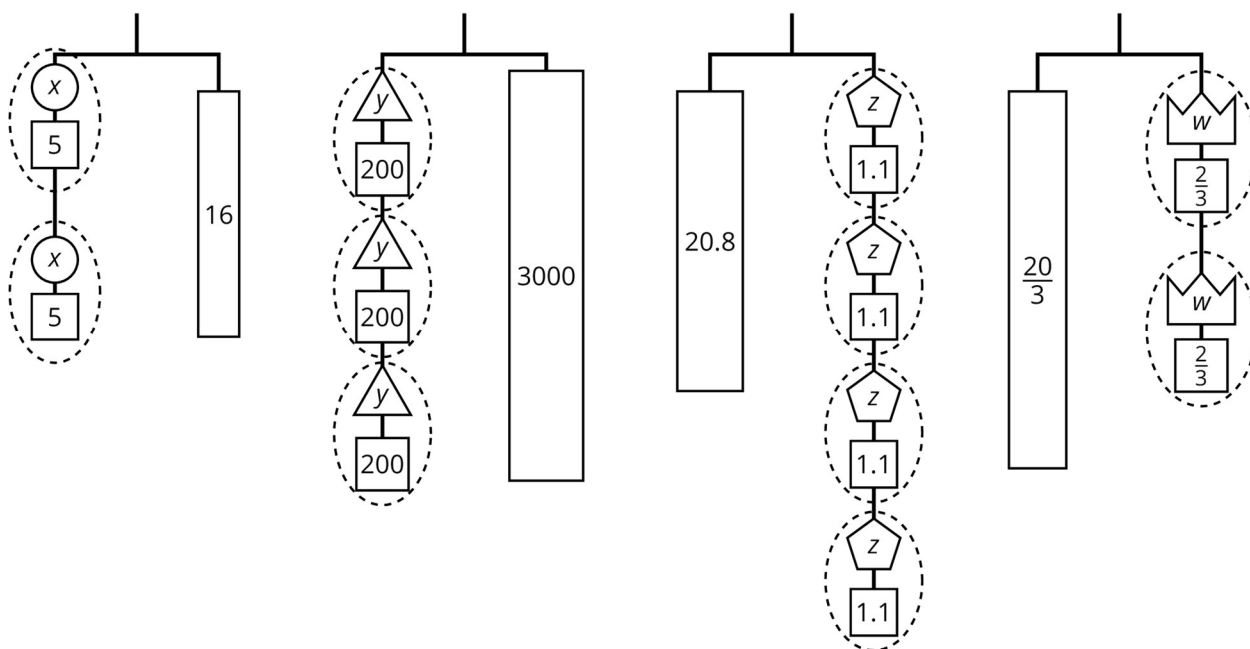

For each diagram:

1. Assign one of these equations to each balance:

$$2(x + 5) = 16$$

$$3(y + 200) = 3000$$

$$20.8 = 4(z + 1.1)$$

$$\frac{20}{3} = 2\left(w + \frac{2}{3}\right)$$

2. Explain how to figure out the weight of a piece labelled with a letter by reasoning about the diagram.

-
3. Explain how to figure out the weight of a piece labelled with a letter by reasoning about the equation.

Student Response

- Each equation corresponds to the diagram with the variable that matches.
- Sample reasoning for the first diagram:
 - Split each side into two groups with $x + 5$ on the left and 8 on the right. From one of these groups, remove 5 units from each side. This shows that $x = 3$.
 - Rearrange the left side so that there are 2 x 's on top and 10 units on the bottom. Remove 10 units of weight from each side, leaving 2 x 's on the left and 6 on the right. Each x must weigh 3 units for the balance to be in balance.
- Sample reasoning for $2(x + 5) = 16$:
 - Divide each side by 2, leaving $x + 5 = 8$. Subtract 5 from each side, leaving $x = 3$.
 - Use the distributive property to write $2x + 10 = 16$. Subtract 10 from each side leaving $2x = 6$. Divide each side by 2 leaving $x = 3$.

Activity Synthesis

Select one balance for which one student divided by p first and another student distributed p first. Display the two solution methods side by side, along with the balance.

Representing, Conversing: Compare and Connect. Use this routine to prepare students for the whole-class discussion. Give students quiet think time to consider what is the same and what is different about the two solution methods. Next, ask students to discuss what they noticed with a partner. Listen for and amplify mathematical language students use to describe how each solution method can be represented by the balance.

Design Principle(s): Cultivate conversation

Lesson Synthesis

Display the equation $4(x + 7) = 40$. Ask one partner to solve by dividing first and the other to solve by distributing first. Then, check that they got the same solution and that it makes the equation true. If they get stuck, encourage them to draw a diagram to represent the equation.

8.4 Solve Another Equation

Cool Down: 5 minutes

Student Task Statement

Solve the equation $3(x + 4.5) = 36$. If you get stuck, use the diagram.

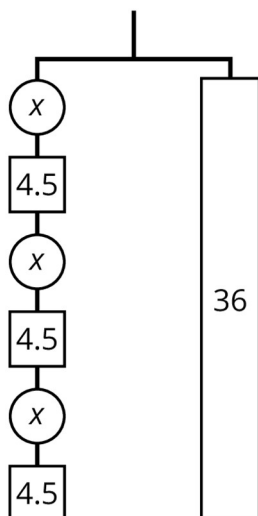

Student Response

$$x = 7.5$$

Sample reasoning:

- Divide each side by 3 leaving $x + 4.5 = 12$ then subtract 4.5 from each side.
- The distributive property gives $3x + 13.5 = 36$. Subtract 13.5 from each side leaving $3x = 22.5$. Divide each side by 3.

Student Lesson Summary

The balanced balance shows 3 equal, unknown weights and 3 2-unit weights on the left and an 18-unit weight on the right.

There are 3 unknown weights plus 6 units of weight on the left. We could represent this balanced balance with an equation and solve the equation the same way we did before.

$$\begin{aligned} 3x + 6 &= 18 \\ 3x &= 12 \\ x &= 4 \end{aligned}$$

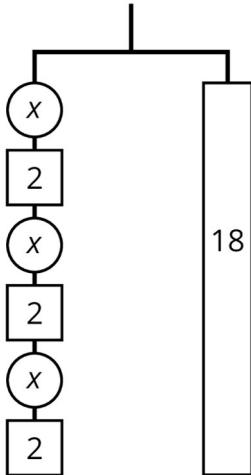

Since there are 3 groups of $x + 2$ on the left, we could represent this balance with a different equation: $3(x + 2) = 18$.

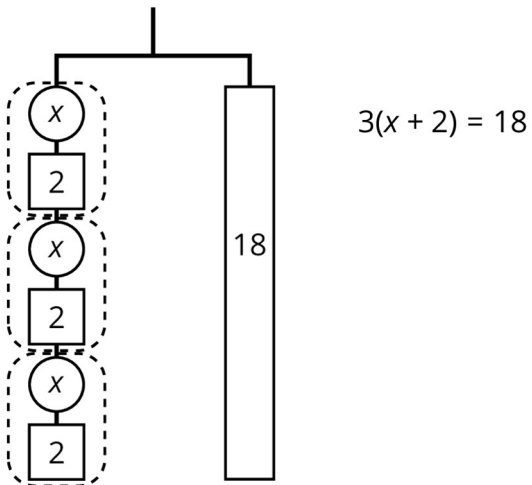

The two sides of the balance balance with these weights: 3 groups of $x + 2$ on one side, and 18, or 3 groups of 6, on the other side.

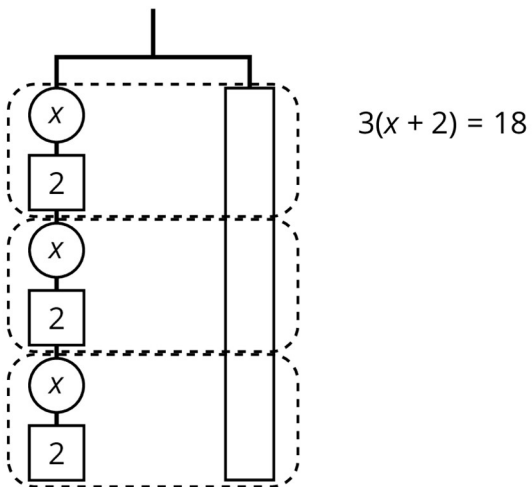

The two sides of the balance will balance with $\frac{1}{3}$ of the weight on each side: $\frac{1}{3} \times 3(x + 2) = \frac{1}{3} \times 18$.

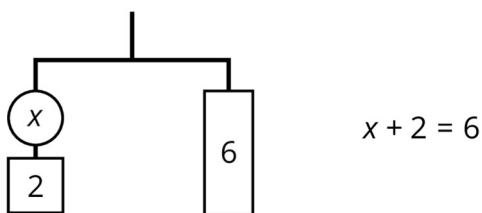

We can remove 2 units of weight from each side, and the balance will stay balanced. This is the same as subtracting 2 from each side of the equation.

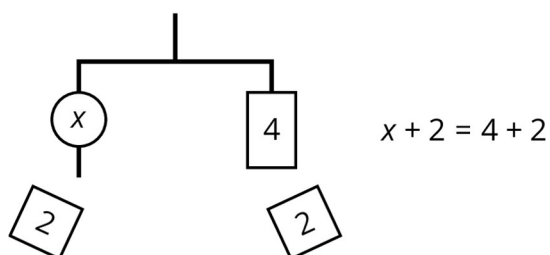

An equation for the new balanced balance is $x = 4$. This gives the solution to the original equation.

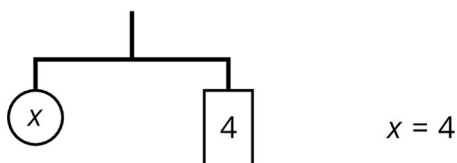

Here is a concise way to write the steps above:

$$3(x + 2) = 18$$

$$x + 2 = 6 \quad \text{after multiplying each side by } \frac{1}{3}$$

$$x = 4 \quad \text{after subtracting 2 from each side}$$

Lesson 8 Practice Problems

1. Problem 1 Statement

Here is a balance:

- Write an equation to represent the balance.
- Solve the equation by reasoning about the equation or the balance. Explain your reasoning.

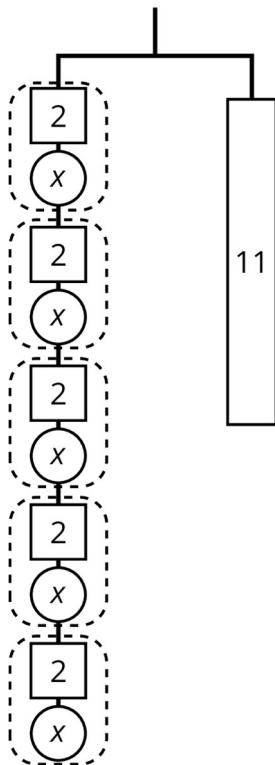

Solution

- a. $5(x + 2) = 11$
- b. $x + 2 = 2.2$ so $x = 0.2$. Explanations vary. Sample explanation: Divide both sides by 5 to get a circle labelled x and a rectangle labelled 2 on the left, and a rectangle labelled 2.2 on the right. Then subtract 2 from each side to get a circle on the left and rectangle with 0.2 on the right.

2. Problem 2 Statement

Explain how each part of the equation $9 = 3(x + 2)$ is represented in the balance.

- x
- 9
- 3
- $x + 2$
- $3(x + 2)$
- the equal sign

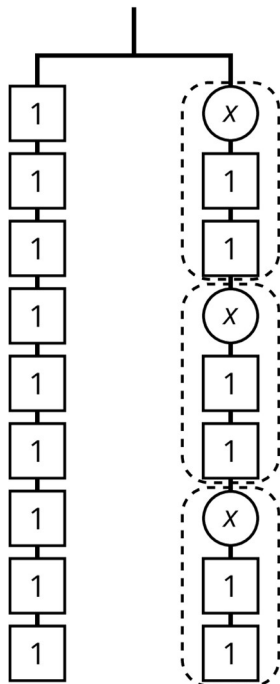

Solution

Answers vary. Sample response:

- The circle has an unknown weight, so use x to represent it.
- The left side has 9 squares, each weighing 1 unit.
- There are 3 identical groups on the right side.
- Each group on the right side is made up of one circle with weight x units and 2 squares of weight 1 unit each.
- The total weight of those 3 identical groups is the total weight of the right side.
- The equals sign is seen in the balance being balanced.

3. Problem 3 Statement

Select the word from the following list that best describes each situation.

- A. You deposit money in a savings account, and every year the amount of money in the account increases by 2.5%.
- B. For every car sold, a car salesman is paid 6% of the car's price.
- C. Someone who eats at a restaurant pays an extra 20% of the food price. This extra money is kept by the person who served the food.

- D. An antique furniture store pays £200 for a chair, adds 50% of that amount, and sells the chair for £300.
- E. The normal price of a mattress is £600, but it is on sale for 10% off.
- F. For any item you purchase in Texas, you pay an additional 6.25% of the item's price to the state government.
1. Tax
 2. Commission
 3. Discount
 4. Markup
 5. Tip or gratuity
 6. Interest

Solution

- A: 6
- B: 2
- C: 5
- D: 4
- E: 3
- F: 1

4. Problem 4 Statement

Clare drew this diagram to match the equation $2x + 16 = 50$, but she got the wrong solution as a result of using this diagram.

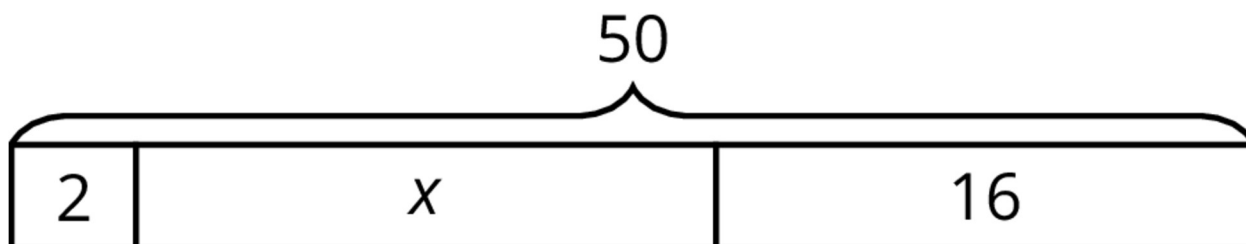

- a. What value for x can be found using the diagram?

-
- b. Show how to fix Clare’s diagram to correctly match the equation.
 - c. Use the new diagram to find a correct value for x .
 - d. Explain the mistake Clare made when she drew her diagram.

Solution

- a. 32. x can be found by subtracting 2 and 16 from 50 since the three parts 2, x , and 16 sum to 50 in the diagram.
- b. The diagram correctly represents the equation if the first block is changed from 2 to x . Then the three parts of the diagram are x , x , and 16, for a total of $2x + 16$.
- c. Since the corrected diagram shows that the number 50 is divided into parts of size x , x and 16, the two x 's must together equal 16 less than 50, which is 34. This means that one x is 17.
- d. Sample explanation: Clare showed $2 + x$ instead of $2 \times x$. She might not understand that $2x$ means 2 multiplied by x , or she might not understand that the bar model shows parts adding up to a whole.



© These materials were derived and adapted from Illustrative Mathematics's IM 6–8 Math™. IM 6–8 Math was originally developed by Open Up Resources and authored by Illustrative Mathematics®, and is copyright 2017–2019 by Open Up Resources. It is licensed under the Creative Commons Attribution 4.0 International License (CC BY 4.0) <https://creativecommons.org/licenses/by/4.0/>. OUR's 6–8 Math Curriculum is available at <https://openupresources.org/math-curriculum/>. Adaptations and updates to IM 6–8 Math™ are copyright 2019 by Illustrative Mathematics®, and are licensed under the Creative Commons Attribution 4.0 International License (CC BY 4.0). Further adaptations have been made by MEI.