

Lesson 16: Applying volume and surface area

Goals

- Apply reasoning about surface area and volume of prisms as well as proportional relationships to calculate how much the material to build something will cost, and explain (orally and in writing) the solution method.

Learning Targets

- I can solve problems involving the volume and surface area of children's play structures.

Lesson Narrative

In this second lesson on applying surface area and volume to solve problems, students solve more complex real-world problems that require them to choose which of the two quantities is appropriate for solving the problem, or whether both are appropriate for different aspects of the problem. They use previous work on ratios and proportional relationships, thus consolidating their knowledge and skill in that area.

Addressing

- Solve real-life and mathematical problems involving angle measure, area, surface area, and volume.
- Solve real-world and mathematical problems involving area, volume and surface area of two- and three-dimensional objects composed of triangles, quadrilaterals, polygons, cubes, and right prisms.
- Analyse proportional relationships and use them to solve real-world and mathematical problems.

Instructional Routines

- Clarify, Critique, Correct
- Compare and Connect

Student Learning Goals

Let's explore things that are proportional to volume or surface area.

16.1 You Decide

Warm Up: 5 minutes

This activity reinforces what students learned in the previous lesson. Students are given two contextual situations and determine if the situation requires surface area or volume to be calculated.

Launch

Arrange students in groups of 2. Give students 1 minute of quiet work time followed by time to discuss their reasoning with a partner. Follow with a whole-class discussion.

Student Task Statement

For each situation, decide if it requires Noah to calculate surface area or volume. Explain your reasoning.

1. Noah is planning to paint the bird house he built. He is unsure if he has enough paint.
2. Noah is planning to use a box with a trapezium-shaped base to hold modelling clay. He is unsure if the clay will all fit in the box.

Student Response

1. Surface area. The surface area is what Noah will calculate because he would need to calculate how much area he needs to cover on the surface of the bird house.
2. Volume. The volume is what Noah will calculate because he needs to calculate how much space the box has inside of it to determine if it will hold all of his clay.

Activity Synthesis

Select students to share their responses. Ask students to describe why the bird house situation calls for surface area and why the clay context calls for volume. To highlight the differences between the two uses of the box, ask:

- “What are the differences in how Noah is using the boxes in these situations?”
- “How can you determine if a situation is asking you to calculate surface area or volume?”

The goal is to ensure students understand the differences between situations that require them to calculate surface area and volume.

16.2 Foam Play Structure

15 minutes

In this activity, students apply what they have learned previously about surface area and volume to different situations. Students have to consider whether they are finding the surface area or volume before answering each question. In addition, students apply proportional reasoning to find the cost of the vinyl that is needed. This is an opportunity for students to revisit this prior understanding in a geometry context.

As students work on the task, monitor for students who are using different methods to decompose or compose the base of the object to calculate the area.

Instructional Routines

- Compare and Connect

Launch

Arrange students in groups of 2. Make sure students are familiar with the terms “foam” and “vinyl.” For example, it may help to explain that many binders are made out of cardboard covered with vinyl. In the diagram, all measurements have been rounded to the nearest inch.

Give students 3–5 minutes of quiet work time followed by time to share their answers with a partner. Follow with a whole-class discussion.

Representation: Internalise Comprehension. Activate or supply background knowledge by reviewing an image or video of a foam play structure. Allow students to use calculators to ensure inclusive participation in the activity.

Supports accessibility for: Memory; Conceptual processing

Anticipated Misconceptions

For the first question, students may try to figure out the total mass of foam needed instead of the total volume. Point out that they are not given any information about how much the foam weighs and prompt them to look for a different way of answering the question “how much foam?”

Some students might see the 0.8p for the unit price and confuse that with £0.80. Remind students of their work with fractional percentages in a previous unit and that 0.8p must be less than 1p.

Student Task Statement

At a daycare, Kiran sees children climbing on this foam play structure.

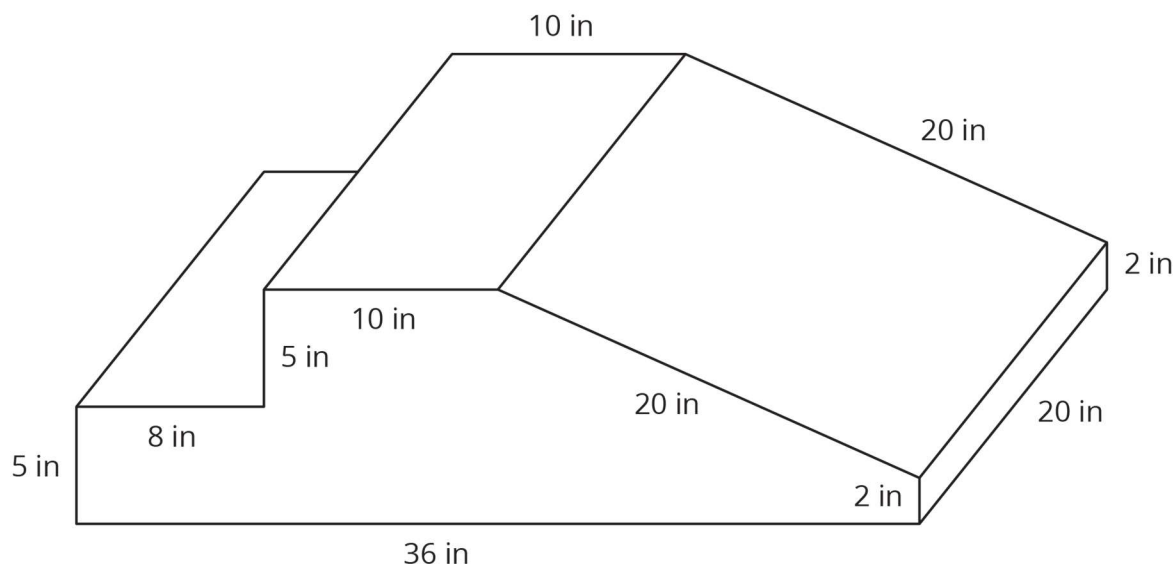

Kiran is thinking about building a structure like this for his younger cousins to play on.

1. The entire structure is made out of soft foam so the children don't hurt themselves. How much foam would Kiran need to build this play structure?
2. The entire structure is covered with vinyl so it is easy to wipe clean. How much vinyl would Kiran need to build this play structure?
3. The foam costs 0.8p per in^3 . Here is a table that lists the costs for different amounts of vinyl.

vinyl (in^2)	cost (£)
75	0.45
125	0.75

What is the total cost for all the foam and vinyl needed to build this play structure?

Student Response

1. The volume of the play structure is $4\,960 \text{ in}^3$, because the area of the base is 248 in^2 and $248 \times 20 = 4\,960$. Possible strategy:

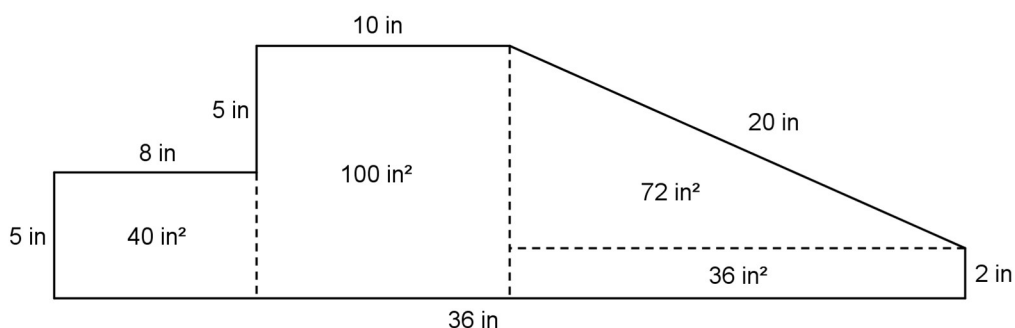

2. The surface area of the play structure is $2\,216 \text{ in}^2$, because the perimeter of the base is 86 in and $86 \times 20 + 248 \times 2 = 2\,216$.
3. The total cost is £52.98. The foam will cost £39.68 because $4\,960 \times 0.008 = 39.68$. The vinyl will cost £13.30, because $2\,216 \times 0.006 = 13.296$. The total cost is £52.98, because $39.68 + 13.30 = 52.98$.

Are You Ready for More?

When he examines the play structure more closely, Kiran realises it is really two separate pieces that are next to each other.

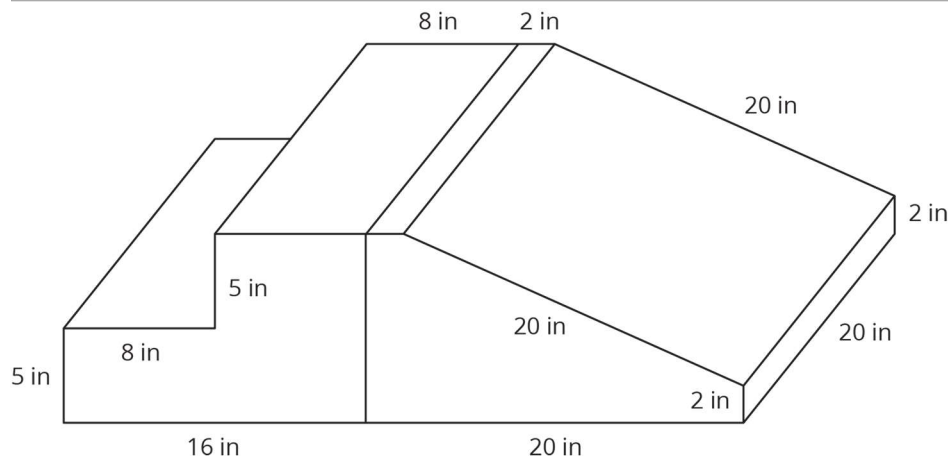

1. How does this affect the amount of foam in the play structure?
2. How does this affect the amount of vinyl covering the play structure?

Student Response

1. The volume of foam stays the same.
2. The surface area increases by 400 in^2 , because there are two new faces, each with an area of 20×10 , or 200 in^2 .

Activity Synthesis

Select previously identified students to share how they calculated the area of the base.

Consider asking some of the following questions:

- “Are there other ways to calculate the area of the base?”
- “How did you know if you had to calculate surface area or volume for this problem?”
- “If Kiran buys a big block of foam that is 36 inches wide, 20 inches deep, and 10 inches tall and cuts it into this shape, what shapes would he be cutting off?” (A cuboid for the step on the left side and a triangular prism for the slide part on the right.)
- “How much more would the big block of foam cost than your calculations?” (This method wastes a volume of $36 \times 20 \times 10 - 4960 = 2240$ cubic inches of foam. This would be an extra £17.92 since $2240 \times 0.008 = 17.92$.)
- If Kiran decides not to cover the bottom of the structure with vinyl, how much would he save?” (This reduces the area of vinyl needed by another $36 \times 20 = 720$ square inches. This would save £4.32 since $720 \times 0.006 = 4.32$.)

Conversing, Listening: Compare and Connect. Use this routine when students share their strategies for calculating the volume of the play structure. Ask students to consider what is the same and what is different about each approach. In this discussion, listen for and amplify comments that refer to the way the shape was decomposed. Draw students’

attention to the various ways area and perimeter of the base were found and how these were represented in each strategy. These exchanges can strengthen students' mathematical language use and reasoning based on volume and surface area.

Design Principle(s): Maximise meta-awareness

16.3 Filling the Sandbox

10 minutes

This activity provides another opportunity for students to apply what they have previously learned about surface area and volume to different situations. Students will practice using proportions as they apply to volumes of prisms in a real-world application.

As students work on the task, monitor for students who use different strategies to answer the questions.

Instructional Routines

- Clarify, Critique, Correct

Launch

Arrange students in groups of 2. If desired, have students close their books or devices and display this regular hexagon with the dimensions of the sandbox in the problem for all to see. Ask students to calculate the base area of the sandbox.

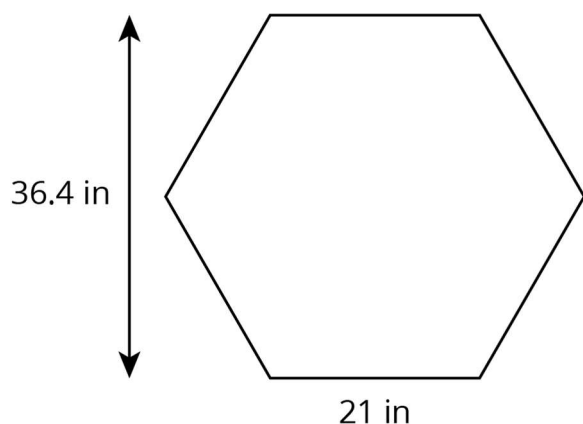

Give students 2–3 minutes of quiet work time followed by time to discuss their work with a partner. Follow with a whole-class discussion.

Action and Expression: Internalise Executive Functions. Chunk this task into more manageable parts to support students who benefit from support with organisational skills in problem solving. For example, present one question at a time.

Supports accessibility for: Organisation; Attention

Anticipated Misconceptions

Students may think that Andre's father needs to purchase 15 bags of sand, because they rounded their answers to 5 and 10 for the individual sandboxes and then added $5 + 10 =$

15. Point out to students that he could pour some of the sand from the same bag into both sandboxes.

Student Task Statement

The daycare has two sandboxes that are both prisms with regular hexagons as their bases. The smaller sandbox has a base area of $1\,146\text{ in}^2$ and is filled 10 inches deep with sand.

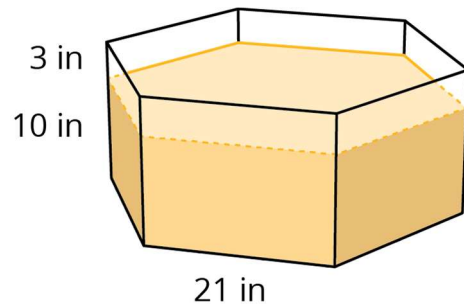

1. It took 14 bags of sand to fill the small sandbox to this depth. What volume of sand comes in one bag? (Round to the nearest whole cubic inch.)
2. The daycare manager wants to add 3 more inches to the depth of the sand in the small sandbox. How many bags of sand will they need to buy?
3. The daycare manager also wants to add 3 more inches to the depth of the sand in the large sandbox. The base of the large sandbox is a scaled copy of the base of the small sandbox, with a scale factor of 1.5. How many bags of sand will they need to buy for the large sandbox?
4. A lawn and garden store is selling 6 bags of sand for £19.50. How much will they spend to buy all the new sand for both sandboxes?

Student Response

1. 819 cubic inches of sand. The volume of the sand that is already there is $11\,460\text{ in}^3$ since $1\,146 \times 10 = 11\,460$. Since 14 bags were used, each bag must have 819 cubic inches inside, because $11\,460 \div 14 \approx 819$.
2. 5 bags of sand. One way to think about it is that it took 14 bags to fill it to a depth of 10 inches. To fill it another 3 inches, it will take $\frac{3}{10}$ as many bags as the previous time. Since we can't buy part of a bag, we round up to 5 bags, because $\frac{3}{10} \times 14 = 4.2$.
3. 10 bags of sand. One way to think about it is that the larger sandbox's dimensions are all multiplied by 1.5, so the area is multiplied by 2.25, because $1.5 \times 1.5 = 2.25$. Since the needed depth of sand is the same, the volume is also multiplied by 2.25, so $2.25 \times 4.2 = 9.45$.
4. £45.50. Andre's father needs to purchase a total of 14 bags of sand, because $4.2 + 9.45 = 13.65$. At £3.25 each, that would cost 14×3.25 , or £45.50.

Activity Synthesis

Select previously identified students to share their methods of solving the problem. Consider asking the following questions:

- “Are there any other ways to solve this problem?”
- “Did you use any answers from one question (or multiple questions) to help you answer another question? If so, why?”
- “Did you use volume or surface area to help you answer any questions?” (yes, volume)
- “How did you calculate how much the daycare would spend on sand?”

Writing: Clarify, Critique, Correct. Present an incorrect statement that reflects a possible misunderstanding from the class for the number of bags Andre’s dad needs to purchase. For example, an incorrect statement is: “Andre’s dad needs to buy 15 sandbags because the small sandbox needs 5 bags and the larger sandbox needs 10 bags.” Prompt students to critique the solution (e.g., ask students, “Is this answer reasonable? Why or why not?”), and then write feedback to the author that identifies how to improve the solution and expand on his/her work. Listen for students who tie their feedback directly to the problem context (e.g., asking, “Why can’t one bag be used for both sandboxes?” or “How much sand will be left over?”) and use the language of volume, surface area, and perimeter. This will help students evaluate, and improve on, the written mathematical arguments of others and highlight the importance of context when solving problems.

Design Principle(s): Maximise meta-awareness

Lesson Synthesis

- “How do we use volume and surface area to solve more complex real-world problems?” (You may need to calculate volume or surface area to answer a bigger question like how much it would cost to build a toy.)
- “What other skills did you have to use to solve the problems in this lesson?” (ratios and proportional relationships)

Explain to students that many times in real-world problems calculating the volume or surface area is just a small piece of what is needed to be done. There are many other skills involved in solving more complex problems.

16.4 Preparing for the Play

Cool Down: 5 minutes

Student Task Statement

Andre is preparing for the school play. He needs to paint a cardboard box to look like a dresser. The box is a cuboid that measures 5 feet tall, 4 feet long, and $2\frac{1}{2}$ feet wide. Andre does not need to paint the bottom of the box.

1. How much cardboard does Andre need to paint?
2. If one bottle of paint covers an area of 40 square feet, how many bottles of paint does Andre need to buy for this project?

Student Response

1. 75 square feet. $(2.5 \times 4) + 2(5 \times 4) + 2(2.5 \times 5) = 75$
2. 2 bottles of paint. $\frac{75}{40} = 1.875$

Student Lesson Summary

Suppose we wanted to make a concrete bench like the one shown in this picture. If we know that the finished bench has a volume of 10 ft^3 and a surface area of 44 ft^2 we can use this information to solve problems about the bench.



For example,

- How much does the bench weigh?
- How long does it take to wipe the whole bench clean?
- How much will the materials cost to build the bench and to paint it?

To figure out how much the bench weighs, we can use its volume, 10 ft^3 . Concrete weighs about 150 pounds per cubic foot, so this bench weighs about 1 500 pounds, because $10 \times 150 = 1500$.

To figure out how long it takes to wipe the bench clean, we can use its surface area, 44 ft^2 . If it takes a person about 2 seconds per square foot to wipe a surface clean, then it would take about 88 seconds to clean this bench, because $44 \times 2 = 88$. It may take a little less than 88 seconds, since the surfaces where the bench is touching the ground do not need to be wiped.

Would you use the volume or the surface area of the bench to calculate the cost of the concrete needed to build this bench? And for the cost of the paint?

Lesson 16 Practice Problems

1. Problem 1 Statement

A landscape architect is designing a pool that has this top view:

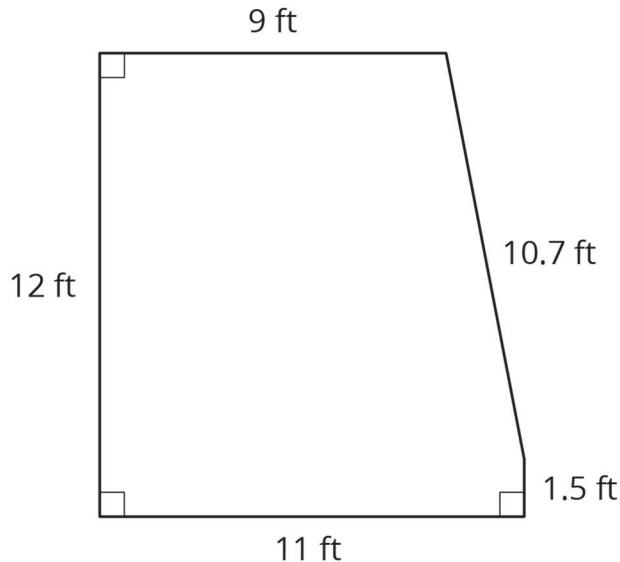

- How much water will be needed to fill this pool 4 feet deep?
- Before filling up the pool, it gets lined with a plastic liner. How much liner is needed for this pool?
- Here are the prices for different amounts of plastic liner. How much will all the plastic liner for the pool cost?

plastic liner (ft ²)	cost (£)
25	3.75
50	7.50
75	11.25

Solution

- 486 ft^3
- 298.3 ft^2
- £44.75

2. Problem 2 Statement

Shade in a base of the trapezium-shaped prism. (The base is not the same as the bottom.)

- Find the area of the base you shaded.

- b. Find the volume of this trapezium-shaped prism.

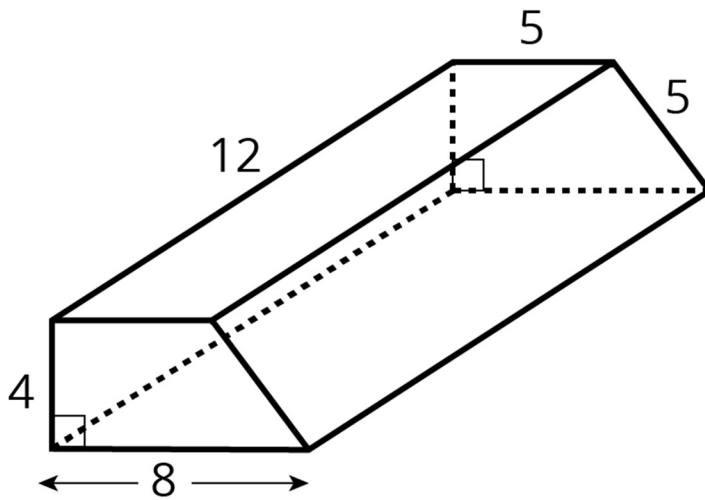

Solution

The bases of the prism are the two trapeziums. Students may shade either the trapezium at the front or the trapezium at the back.

- a. 26
b. 312

3. Problem 3 Statement

For each diagram, decide if y is an increase or a decrease of x . Then determine the percentage that x increased or decreased to result in y .

A

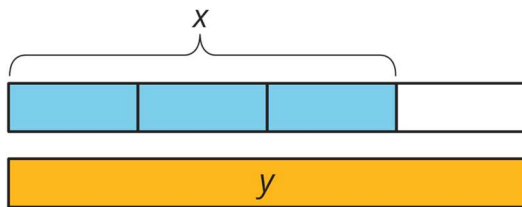

B

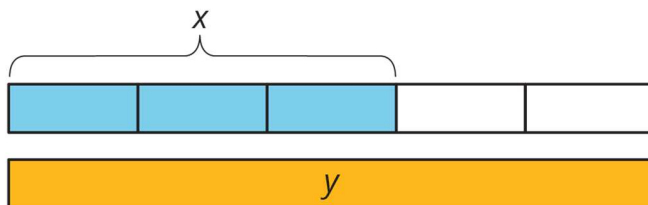

C

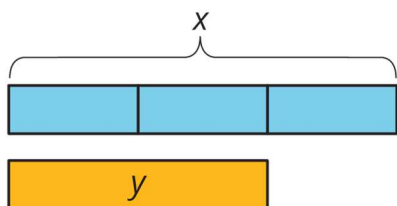

D

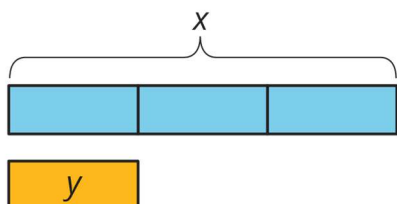

Solution

- a. Increase, $33\frac{1}{3}\%$
- b. Increase, $66\frac{2}{3}\%$
- c. Decrease, $33\frac{1}{3}\%$
- d. Decrease, $66\frac{2}{3}\%$

4. Problem 4 Statement

Noah is visiting his aunt in Texas. He wants to buy a belt buckle whose price is \$25. He knows that the sales tax in Texas is 6.25%. (States in the USA can set their own tax rates.)

- a. How much will the tax be on the belt buckle?
- b. How much will Noah spend for the belt buckle including the tax?
- c. Write an equation that represents the total cost, c , of an item whose price is p .

Solution

- a. \$1.56 (requires rounding)
- b. \$26.56
- c. $c = 1.0625p$ or equivalent



© These materials were derived and adapted from Illustrative Mathematics's IM 6–8 Math™. IM 6–8 Math was originally developed by Open Up Resources and authored by Illustrative Mathematics®, and is copyright 2017–2019 by Open Up Resources. It is licensed under the Creative Commons Attribution 4.0 International License (CC BY 4.0) <https://creativecommons.org/licenses/by/4.0/>. OUR's 6–8 Math Curriculum is available at <https://openupresources.org/math-curriculum/>. Adaptations and updates to IM 6–8 Math™ are copyright 2019 by Illustrative Mathematics®, and are licensed under the Creative Commons Attribution 4.0 International License (CC BY 4.0). Further adaptations have been made by MEI.